

Mudsucker Trash Pump

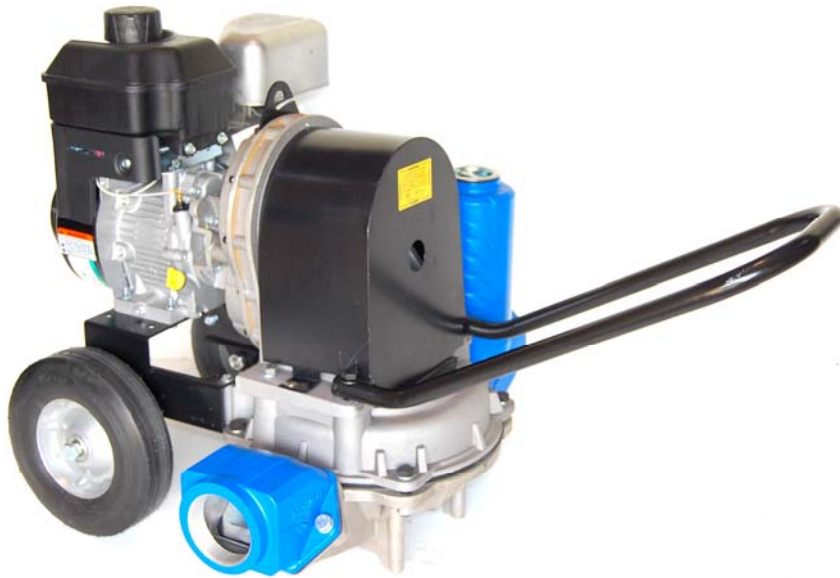

- ◆ Sand Cast Aluminum Construction
- ◆ Thermoplastic Santoprene Diaphragm
- ◆ Gasoline powered
- ◆ 3" NPT Suction / Discharge Ports
- ◆ Maximum Temperature 180 F
- ◆ .075" Keyed Shaft
- ◆ Self priming to 25 Ft. Lift
- ◆ Diaphragm pump
- ◆ Tank Size .052 gal / 2.0 lt
- ◆ Maximum Solids Handling Capacity: 1-5/8" diameter
- ◆ Complete with Oil Alert

Model 56310
3" Capacity

Wheeler-Rex

3744 Jefferson Road
Ashtabula, OH 44004

www.wheelerrex.com

Phone: 800-321-7950 or 440-998-2788

Fax: 440-992-2925

Email: wheeler@wheelerrex.com



Mudsucker Trash Pump

Unpacking

After unpacking the unit, inspect carefully for any damage that may have occurred during transit. Check for loose, missing or damaged parts.

Specific Safety Information for Gasoline Engine Driven Pumps

1. Carefully read the instruction manuals supplied by the engine manufacturer before attempting to assemble/disassemble or operate the engine or any other part. The "Warning" and "Caution" statements in this manual signal potential hazardous conditions to the operator or equipment. Know when these conditions can exist. Take necessary steps to protect personnel as well as equipment.



WARNING

Gasoline is a highly combustible fuel. Use it with care! The improper use, handling and/or storage of gasoline can be dangerous. Help prevent accidents by following these safety rules:

- a. Use gasoline only as fuel, never as a cleaning fluid.
- b. Always use an approved container to hold or store gasoline. Never store gasoline in familiar containers such as milk gallons or soda pop bottles.
- c. Never store gasoline near a heater or an open flame.
- d. When storing or using gasoline, make sure container is out of the reach of children.
- e. Never add gasoline to a running or hot engine. Spilled gasoline on a hot engine may cause a fire or an explosion. Fill gasoline tank outdoors and wipe up any spills.
- f. Have a fire extinguisher nearby. Be sure extinguisher is in operating condition - check the pressure gauge or indicator. Be familiar with its proper use. Consult the local fire department for the correct type of extinguisher for your application. Extinguishers rated ABC by the National Fire Protection Association are appropriated for all applications.
- g. On permanent installations, be sure all fuel supplies have a positive shut-off valve. Fuel lines must be of steel piping, adequately secured and free from leaks. Do not use copper piping or flexible lines as copper becomes hardened and brittle and will break. Use black pipe on natural gas or gaseous fuels, but not on gasoline or diesel fuels. Piping the engine should be a suitable flexible line that is compatible with the fluid.

Positively No Smoking!

2. Check engine oil, fuel levels and gear box oil levels before initial startup each day. Stay away from moving parts due to the danger of becoming caught in moving parts. Avoid loose jackets, shirts, sleeves and ties. Make sure all nuts and bolts are secure. Keep power shields and guards in place. If adjustment MUST be made while the unit is running, use extreme caution around hot manifolds, moving parts etc.
3. Do not work with this equipment when mentally or physically fatigued.
4. Be careful not to touch the exterior of the engine, especially the muffler and the area around it. It is hot enough to be painful or cause injury.
5. To prevent accidental starting, always remove the spark plug or disconnect and ground the spark plug wire before working on the engine or the equipment driven by the engine.

6. DO NOT RUN THE ENGINE IN AN ENCLOSED AREA!!

Exhaust gases contain carbon monoxide, which is an odorless and deadly gas that will cause death if breathed too long. If equipment is located in an enclosed area with an exhaust line to the outside, regularly check the exhaust system for leaks. Be sure the area is well ventilated.

7. If the gas engine is equipped with a spark arrester screen in the muffler, it should be inspected for wear periodically and replaced when necessary.

Specific Safety Information for Electric Motor Driven Pump

1. This unit is not waterproof and is not intended to be used in potentially wet locations. The motor is designed to be used in a clean, dry location with access to an adequate supply of cooling air. Ambient temperature around the motor should not exceed 104° F (40° C). For outdoor installations, motor must be protected by a cover that does not block air flow to and around the motor. This unit is not weatherproof nor is it able to be submersed in water.

2. When wiring an electrically driven pump, follow all electrical and safety codes, as well as the most recent United States National Electrical Code (NEC) and the Occupational Safety and Health Act (OSHA).



WARNING

Risk of electrical shock! Never connect the green (or green and yellow) wire to a live terminal

3. To reduce the risk of electric shock, the motor must be securely and adequately grounded! This can be accomplished by either (1) inserting plug (portable) directly into a properly installed and grounded

Mudsucker Trash Pump

3-prong grounding-type receptacle (as shown in Figure 2); 2 permanently wiring the unit with a grounded metal raceway system. (3) using a separate ground wire connected to the bare metal of the motor frame, or (4) other suitable means. The green (or green and yellow) conductor in the cord is the grounding wire. The motor must be securely and adequately grounded for your protection against shock hazard. Where a 2-prong wall receptacle is encountered, it must be replaced with a properly grounded 3-prong receptacle installed in accordance with the National Electrical Code and local codes and ordinances. To ensure a proper ground, the grounding means best be tested by a qualified electrician. Use only 3-wire extension cords that have 3-prong, grounding-type plugs and 3-pole receptacles that accept the equipment plug.

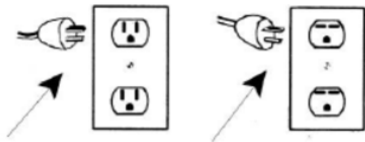

Grounding Blade—Figure 2 Grounding Methods

4. All wiring should be performed by a qualified electrician.



WARNING

An incorrect connection may cause an electric short, produce an electrical shock or burn out the pump motor, resulting in property damage and/or personal injury.

5. Protect electrical cord from sharp objects, hot surfaces, oil and chemicals. Avoid kinking the cord. Replace or repair damaged or worn cords immediately.
6. Provide safety shields on all moving and electrical parts to prevent personal injury.
7. Keep fingers and foreign objects away from ventilation and other openings. Do not insert any objects into the motor.
8. Use wire of adequate size to minimize voltage drop at the motor.
9. Disconnect power before servicing a motor or its load. If the power disconnect is out of sight, lock it in the open position and tag it to prevent unexpected application of power.
10. Do not touch an operating motor. Modern motors are designed to operate at high temperatures.

General Safety Information

1. Know the pump application, limitations and potential hazards.



WARNING

Do not use to pump flammable or explosive fluids such as gasoline, fuel oil or kerosene, etc. Do not use in flammable and/or explosive atmospheres. Pump should only be used with liquids compatible with pump component materials. Failure to follow this warning can result in personal injury and/or property damage.

2. Make certain that the power source conforms to the requirements of your equipment.
3. Provide adequate protection and guarding around moving parts.
4. Disconnect power before servicing.
5. Release all pressure within the system before servicing any component.
6. Drain all liquids from the system before servicing.
7. Secure the discharge line before starting the pump. An unsecured discharge line will whip, possibly causing personal injury and/or property damage.
8. Check hoses for weak or worn condition before each use making certain that all connections are secure.
9. Periodically inspect pump and system components. Perform routine maintenance as required (see Maintenance Section)
10. Provide a means of pressure relief for pumps whose discharge line can be shut off or obstructed.
11. **Personal Safety:**
 - a. Wear safety glasses at all times when working with pumps.
 - b. Wear a face shield and proper apparel when pumping hazardous chemicals.
 - c. Keep work area clean, uncluttered and properly lighted - replace all unused tools and equipment.
 - d. Keep visitors at a safe distance from the work area.
 - e. Make workshop childproof - with padlocks, master switches and by removing starter keys.
12. For air drive units follow Safety Information instruction sheet supplied with air motor.

Mudsucker Trash Pump

Assembly

1. Handle on 2" Pump

- Remove two hex cap screws (Ref No A6) and washers (Ref No A7) from gearbox (Ref No A1).
- Place handle (ref No A35) on gearbox flange and align holes.
- Reinstall two hex cap screws and washer assemblies, then tighten.

Handle on 3" Pump

- Remove two hex nuts (Ref A14) from pump well (Ref No A3).
- Place handle (Ref No A35) under pump well.
- Reinstall two hex nut and washer assemblies then tighten.

2. Rotating suction / discharge ports (optional)

Refer to Figure A.W.P.

In some applications, it may be preferable to have suction / discharge ports rotated 90° to be in line with driver. If so, proceed as below:

- Remove four hex cap screws (Ref No A9), hex cap screws (Ref A13 & A14) from pump assembly to separate pump well (Ref No A3) from pump base (Ref No A8)
- Rotate pump well 90 degrees clockwise so that driver is positioned over top of discharge plate (Ref No W7).
- Be sure that pump well base and diaphragm (Ref No P17) are aligned properly with one another. Then reinstall four hex cap screws, hex nuts and washer assemblies and tighten.

Gear Box Oil (Refer to Figure A, G)

3. Place pump on a level surface. Fill pump gear box (ref No A1) with gear box oil before the pump is operated. Gear oil must meet requirements of API GL-5 and military specification MIL-L-2105B. Remove gear box housing fill plug (Ref No G8). Remove level plug (Ref No G5). Pour gear oil into gear box slowly until oil comes out of level plug.

Warranty on this unit is void unless the gear box is lubricated with appropriate gear oil listed above. DO NOT OVERFILL!!!

Installation

NOTE: In any installation where property damage can occur by pumps not operating due to power outages, discharge line freezing or any other reason, a backup system (s) and/or warning system (s) should be used.

- Place the pump on a level, solid foundation, locating it as close to the liquid as possible making the suction line as short and direct as possible.
- Install pipe nipples (Ref No A36) so the smoother side of pipe end faces the suction and discharge hose.



CAUTION

Maximum discharge head is 25 feet or 10.9psi. Operation over this head or pressure will cause pump to stall and/or gearbox damage. Use only rigid hoses.

3. Attach suction piping to the suction inlet (ref No W2) and discharge piping to the discharge outlet (Ref No W7). The suction line should be positioned such that there is a continual upward slope from the fluid source to the pump. Avoid using loops or sections of pipe or fittings, which might permit air to become trapped.

NOTE: If hose is used, be sure to use reinforced hose on both the suction and discharge. **DO NOT USE** canvas or similar collapsible materials. **NEVER USE PIPE REDUCER; PIPE SIZE MUST BE EQUAL TO OR LARGER THAN THE PUMP PORT SIZE.** Suction line must be airtight so that air cannot leak in and destroy priming vacuum. On a permanent installation where piping is used, always connect a piece of flexible hose between pump and piping so pump is free to move slightly.

4. It is advisable to use a strainer. (Ref No W16) on the inlet end of the suction hose or pipe. A properly sized strainer is supplied with this unit and should be used at all times to prevent damage. Keep the strainer clean. If possible, suspend it to keep it from being clogged with muck., roots, debris or leaves. It is best to keep hose free of kinks as they will restrict flow and add excess loading to pump and gearing.

5. **Gasoline Engine Units:** Follow all instructions in the engine manual before starting the engine. Fill engine with oil, gasoline, etc.

Air Motor Units: Follow all instructions in the air motor manual before starting unit.

Electric Motor Units: It is strongly recommended that this unit is plugged into a G.F.I. (Ground Fault Interrupter) circuit. Consult your local electrician for installation and availability.

6. Input RPM (to pump) - Input RPT must be between 1750 and 2750 RPM. Final pump speed will be 40 strokes/minute with a 1750RPM input and 60 strokes/minute RPM Input.

Mudsucker Trash Pump

Do not exceed 60 strokes per minute with the diaphragm pump.

Operation

Operate the diaphragm pump in an upright position only.

1. This diaphragm pump is capable of priming “dry” up to fifteen feet; it will prime much faster when it is filled with clean water through priming cap (Ref No W6). Primed, it can lift to 25 feet.
2. Activate unit following engine or air motor manual turning unit on if electrical



CAUTION

Do not control discharge capacity with a valve or similar device.

Clearing Jam Up

If large solids or an accumulation of sand or other sediment becomes lodged in the pump well (Ref No A3) preventing the plunger arm (Ref No A2) from making a full stroke, the pump will either stall or the crank (Ref No P5) will slip on the output shaft (Ref No G8). The pump is designed to react this way to prevent severe internal damage. If such a jam-up does occur, the pump should be thoroughly cleaned as described in “If Pump Stalls” within this section. Refer to parts list and illustration for parts identification.



CAUTION

If pump has stopped or stalled for any unknown reason, clean out pump cavity thoroughly. Failure to comply with the “caution” could result in damage to crank (Ref No P5/P9), plunger arm (Ref No P1) or other parts of assembly.

1. If pump stalls:
 - a. Remove handle (Ref No A35).
 - b. Remove four bolts (Ref No A9 & A10)
 - c. Clean obstruction & all debris from pump well (Ref No A3).
 - d. Reassemble pump in reverse order of disassembly and return to service.
2. If Plunger Arm (Ref No P1) seizes and gear box output shaft (Ref No G8) turns in crank (ref No P5):
 - a. Remove sheet metal guard (ref No A4) by loosening hand knob screws (Ref No A5)
 - b. Disassemble pump and clean as described in Steps a thru d listed for stalled engine jam up.
 - c. Torque the crank lock screw (Ref No A6) to 70 foot pounds with an appropriate torque wrench. See Figure 3.

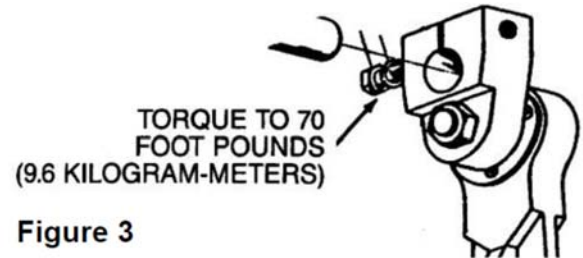

Figure 3

- d. Reassemble the pump in reverse order of disassembly and return to service.



WARNING

Pump jamming with an over-torqued lock screw may cause internal damage. Under torquing may allow the output shaft to spin and wear parts necessitating replacement.

Maintenance



WARNING

Make certain that unit is disconnected from power source before attempting to service or remove any component.

1. Check gear box oil level every 20 hours of operation or at least once a week. More often if any leakage is detected around the gear box. Change gearbox oil after the first 40 hours of operation. Fill to the oil level plug. Change gearbox oil every 350 hours of operation.
2. The plunger bearing (Ref No P3) must be greased (any automotive grease) after every 8 hours of use. This is done by rotating plunger bearing to the 12 o'clock position. At this point, grease fitting will be visible through hole in guard (Ref No A4) Bearing may be cleaned and kept well lubricated by pumping grease slowing into fitting until new grease oozes out between bearing and journal.
3. During freezing weather, be sure to drain the pump when it is not running. Remove discharge hose and tip unit towards discharge side.
4. Keep pump clean. After use with liquids containing foreign materials, flush with clean water.

Replacement of Flapper Valve (Ref No W15)

1. Remove two bolts (ref NO W3) and remove suction priming chamber (Ref No W2). Replace flapper (ref No W15) on flapper pin to locate on priming chamber.
2. Remove two bolts (Ref No W8) and remove

Mudsucker Trash Pump

discharge plate (Ref No W7). Replace flapper valve on flapper pin to locate valve on pump well (Ref No W1)

Replacement of Diaphragm (Ref No P17)

1. Remove sheet metal guard (ref No A4) by loosening hand knob screws (ref No A5)
2. Rotate pump until plunger arm (Ref No A2) is in the down position.
3. Remove handle (Ref No A35)
4. Remove pump well (Ref No A3) by removing screws (Ref No A9/A10)
5. Remove diaphragm by removing three nuts (Ref No P12) from bolts (Ref No P11)
6. Replace diaphragm and reverse steps 1 thru 5 for reassembly.
- 7.

Gear Box Overhauling

A completely assembled gear box is available as a replacement part (Ref No G28).

Disassembly

1. Remove diaphragm (Ref No P13) as described in "Replacement of Diaphragm".
2. Remove crank (Ref No P5) by removing machine screw (Ref No P6). Use screwdriver in slot of crank to release clamp on output shaft (Ref No G8).
3. Drain oil from gear box by removing drain plug (Ref No G4).
4. Remove driver (Ref Nos A28/A32) from adapter (Ref No G26) by removing four bolts (Ref No A27) plus 4 additional bolts (Ref No A29) from engine mount bracket (Ref No A16) for gas driver models. Slide driver back from adapter until driver shaft disengages pinion (Ref No G27).
5. Remove adapter by removing four bolts. (Ref No G27)
6. Remove gear box from pump base (Ref No A8) by removing four bolts (Ref No A9 & A10).
7. Remove pinion bearing assembly (Ref Nos G15, G24, G20, G16) by pulling straight out. Use a slide hammer puller gripping in pinion groove.
8. Remove twelve bolts (Ref No G3) holding gear box halves (Ref Nos G1 & G2) together.
9. Carefully separate gearbox halves.
10. Remove gasket (Ref No G22)
11. Remove output shaft/bearing assembly (Ref Nos G8, G9, G12, G11, G12, G13) and idler pinion/bearing assembly (Ref Nos G13, G14, G17, G18, G19)

12. Remove output shaft oil seal (Ref No G23)
13. Remove bearings (Ref Nos G15 & G18) from ends of input pinion shaft (Ref No G20)
14. Remove bearings (Ref Nos G13 & G14) from ends of idler pinion shaft (Ref No G20).
15. Remove internal spur gear (Ref No G19) and key (Ref No G18) from idler pinion shaft.
16. Remove retaining ring (Ref No G10) and bearings (Ref Nos G12 & G13) from ends of output shaft (Ref No G8).
17. Remove output gear (Ref No G11) and key (Ref No G9) from output shaft.

Reassembly

1. Assemble input pinion/bearing assembly, idler pinion bearing assembly and output shaft/bearing assembly.
2. Install output shaft oil seal into gearbox output half. Lubricate lip seal.
3. Slide output shaft through lip seal. Start output bearing in bore in gear box output half. Simultaneously press both assemblies into output half.
4. Install gasket on output half.
5. Position gear box input half, align shaft bearings with bearing bores. Press gear box halves together, align pins in output half with pin bore in input half.
6. Secure halves together with twelve bolts.
7. Slide input pinion/bearing assembly into bore in gear box input half. Rotate pinion during installation to make sure gear teeth align with internal spur gear teeth.
8. Install O-Ring (Ref No G25) on outside of pinion bearing.
9. Reassembly gear box to pump base with four bolts.
10. Reassembly adapter to gear box with four bolts.
11. Align driver shaft key (Ref No A26) with keyway in pinion. Slide driver into position, secure to adapter with four bolts (Ref No A27).
 - a. (Gas Engine Only) Attach engine to engine mount with four additional screw assemblies (Ref No A29).
12. Reassemble crank to output shaft as described under "Replacement of Diaphragm" section.
13. Replace diaphragm as described under "Replacement of Diaphragm" section.
14. Fill gear box with oil as described under "Assembly" section.
15. Pump should be checked daily, weekly, monthly for proper operation.

Mudsucker Trash Pump

NOTE:

Only qualified service personnel should attempt to repair this unit. Improper repair and/or assembly can cause pump damage, driver damage and/or an electrical shock hazard depending on the model.

Diaphragm Pumps

Symptom	Possible Cause(s)	Corrective Action
Pump will not prime or retain prime after operating	<ol style="list-style-type: none">1. Air leak in suction line2. Defective flapper valves3. Clogged foot valve or strainer4. No liquid in suction line5. Material jammed in pump well	<ol style="list-style-type: none">1. Repair or replace2. Replace3. Clean or replace4. Fill suction line & pump with liquid5. Clean (See Maintenance)
Flow rate is slow	<ol style="list-style-type: none">1. Incorrect driver speed2. Piping is fouled or damaged3. Clogged pump4. Discharge line restricted or undersized5. Collapsible discharge hose6. Too many bends7. Lines are too long	<ol style="list-style-type: none">1. Increase speed (see Specifications)2. Clean or replace3. Clean4. Flush out piping or replace5. Replace with rigid or non-collapsible hose6. Straighten hose7. Shorten lines
Pump runs but no fluid	<ol style="list-style-type: none">1. Faulty suction piping2. Pump located too far from fluid source3. Gate valve closed4. Clogged strainer5. Discharge height too great	<ol style="list-style-type: none">1. Replace2. Place pump closer to source3. Open gate valve4. Clean or replace5. Lower discharge height
Pump starts and stops pumping	<ol style="list-style-type: none">1. Leak in suction line2. Leak in foot valve3. Diaphragm has a crack or hole4. Defective or clogged flapper valves	<ol style="list-style-type: none">1. Repair2. Repair or replace3. Replace4. Clean or replace
Excessive noise while pump in operation	<ol style="list-style-type: none">1. Pump not secured to firm foundation2. Restricted suction line	<ol style="list-style-type: none">1. Secure properly2. Clean or correct
Pump stalls repeatedly or stops for no apparent reason	<ol style="list-style-type: none">1. Discharge height over 25 feet of head2. Material jammed in pump well	<ol style="list-style-type: none">1. Lower height (see Specifications)2. Clean out pump well (See Operation & Maintenance section)

Mudsucker Trash Pump

Repair Parts List - Engine Chart

Please provide following information:

-Model Number

-Serial Number (if any)

Part description and number as shown in parts list

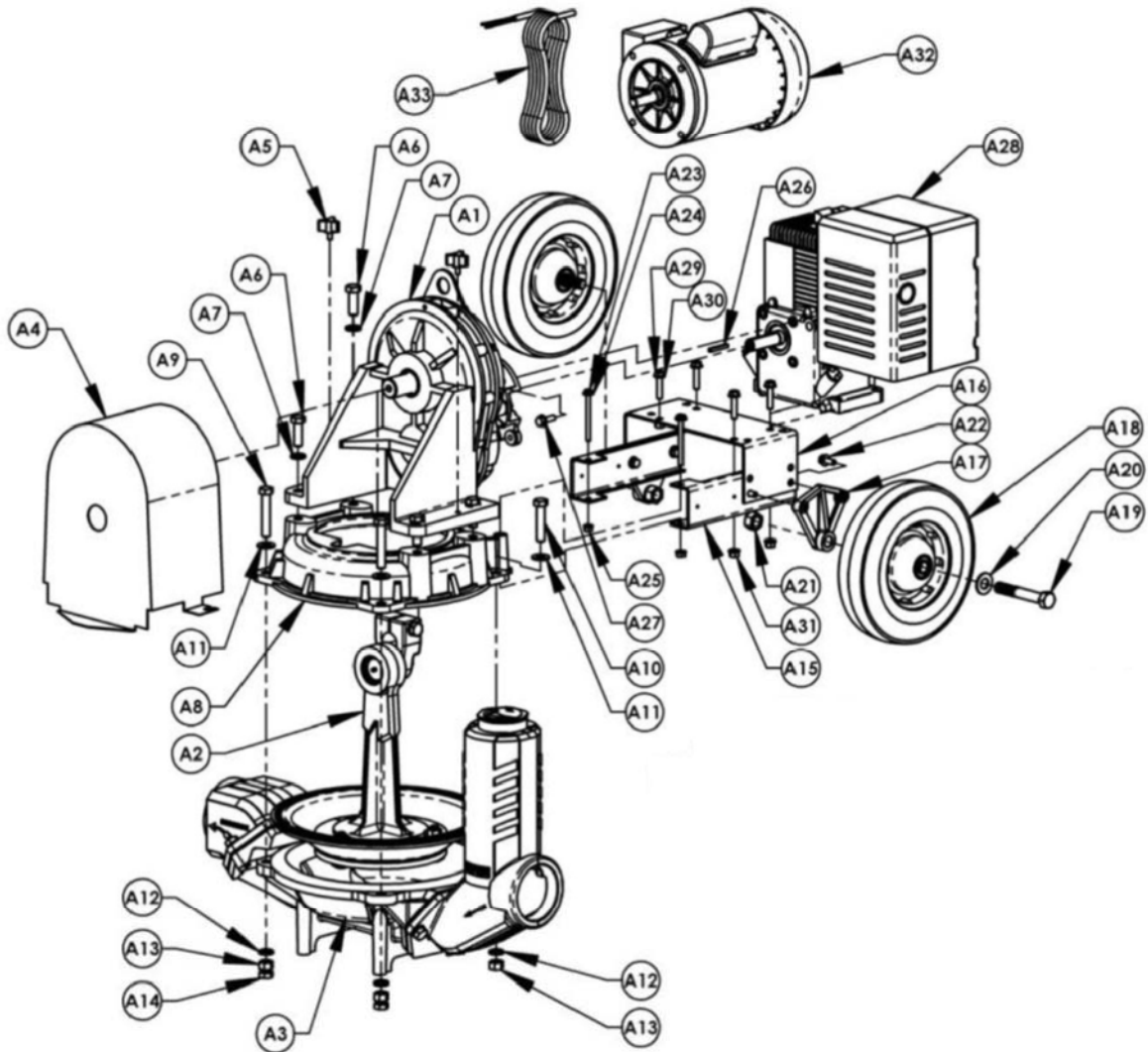

Assembled Pump – Figure A

Mudsucker Trash Pump

Repair Parts List - Assembled Pump

Ref. No.	Description	3" Engine Driven Pump Part Number	3" Motor Driven Pump Part Number
A1	Gearbox Assembly	Ref. Page 8	Ref. Page 8
A2	Plunger/Diaphragm Assembly	Ref.	
A3	Well Assembly	Ref. Page 11	Ref. Page 11
A4	Plunger Guard	3354-103-00	3354-103-00
A5	1/4-20X1/2 Plastic Knob	1716-010-00	1716-010-00
A6	1/2-13x1-1/2 Hex Head Cap Screw	1766-013-00	1766-013-00
A6	1/2-13x2-1/4 Hex Head Cap Screw	1766-016-00	1766-016-00
A7	1/2 Lock Washer	1798-001-00	1798-001-00
A8	Base	3354-001-01	3354-001-01
A9	1/2-13x2-3/4 Hex Head Bolt Grade-5	1766-018-00	1766-018-00
A9	1/2-13x2-1/4 Hex Head Bolt Grade-5	N/A	N/A
A10	1/2-13x2-1/4 Hex Head Bolt Grade-5	1766-016-00	1766-016-00
A11	1/2 Flat Washer	1798-002-00	1798-002-00
A12	1/2 Lock Washer	1798-001-00	1798-001-00
A13	1/2-13 Hex Nut	1782-002-00	1782-002-00
A14	1/2-13 Hex Jam Nut	1782-001-00	1782-001-00
A15	Mount Brace	3354-107-00	3354-107-00
A16	Engine Mount	3354-108-00	3354-108-00
A16	Engine Mount Kit for Hatz	335Z-101-90	N/A
A17	Wheel Bracket	3354-109-00	3354-109-00
A18	Wheel	1663-000-00	1663-000-00
A19	5/8-11x4 Hex Head Bolt	1769-000-00	1769-000-00
A20	5/8 Flat Washer	1799-000-00	1799-000-00
A21	5/8-11 Hex Nut	1782-020-00	1782-020-00
A22	5/16-18x3/4 Hex Flange Screw	1745-002-00	1745-002-00
A23	1/4-20x3 Hex Head Bolt	1734-013-00	1734-013-00
A24	1/4 Flat Washer	1789-000-00	1789-000-00
A25	1/4-20 Hex Nut	1776-000-00	1776-000-00
A26	3/16 Square Key	1517-001-00	1517-001-00
A27	5/16-24x1 Hex Flange Screw	1753-000-00	N/A
A27	3/8-16X1-1/4 Hex Head Cap Screw	N/A	1757-003-00
A28	Engine 3/4 Keyed PTO	See Chart	N/A
A29	5/16-18x1-1/2 Hex Head Bolt	1748-000-00	N/A
A29	5/16-18 x 3/4 Hex Bolt (Hatz)	1745-002-00	N/A
A30	5/16 Flat Washer	1790-000-00	N/A
A31	5/16-18 Hex Nut	1785-000-00	N/A
A32	Motor	N/A	1026-095-00
A33	Cord Assembly	N/A	335E-352-90
A34	Switch Assembly (not shown)	N/A	335E-351-90
A35	Handle Kit (not shown)	3354-116-90	3354-116-90
A36	Nipple Pack (2 NPT nipples)	3270-170-00	3270-170-00
A28	Honda GX120UT1QX2	335G-96	
A28	Honda GX160UT1QX2	335H-96	
A28	Hatz 1B20	335Z-96	

Mudsucker Trash Pump

Please provide following information:

-Model Number

-Serial Number (if any)

Part description and number as shown in parts list

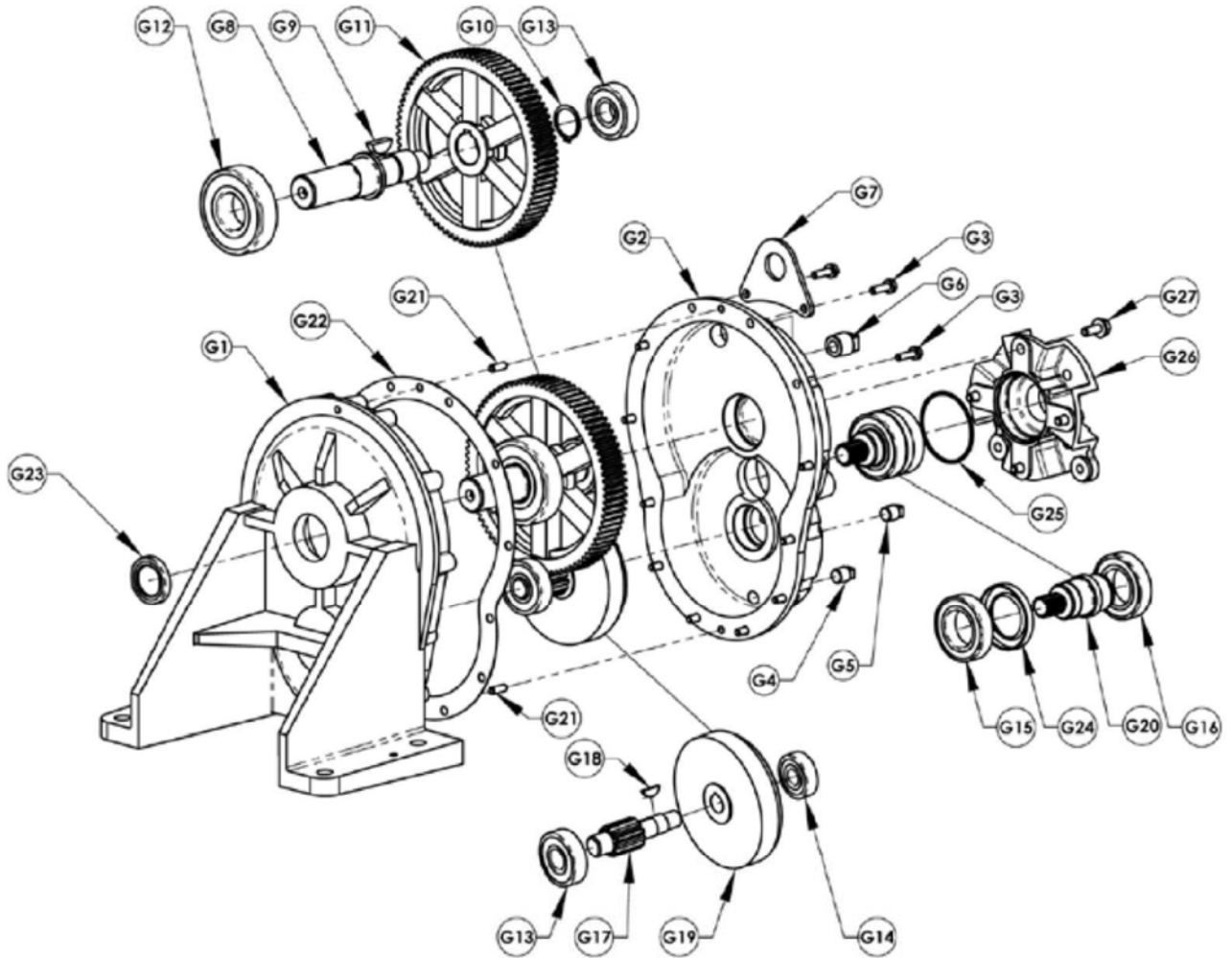

Gearbox – Figure G

Mudsucker Trash Pump

Repair Parts List - Gearbox

Ref. No.	Description	3" Pumps Part Number	Qty.
G1	Gearbox Output Half	3354-090-01	1
G2	Gearbox Input Half	3354-091-01	1
G3	¼-20x7/8" Screws and Washer Kit (12 each)	3354-420-90	1
G4	¼ NPT Plug (drain) (kit includes 1)	1767-002-00	1
G5	¼ NPT Plug (oil level) (kit includes 1)	1767-002-00	1
G6	½ NPT Vented Plug (fill) (kit includes 1)	1767-001-00	1
G7	Lift Bracket	3354-106-00	1
G8	Output Shaft	3354-140-00	1
G9	Woodruff Key #1008	2141-000-00	1
G10	External Retaining Ring SH-112	1806-064-00	1
G11	Output Gear	3354-120-00	1
G12	Bearing –Open- 35x80x21 #6307 JEM	3354-190-00	1
G13	Bearing –Open- 20x52x15 #6304 JEM	3354-191-00	2
G14	Bearing –Open- 15x42x13 #6302 JEM	3354-192-00	1
G15	Bearing –Open- 35x62x14 #6007 JEM	3354-194-00	1
G16	Bearing –Sealed- 35x62x14 #6007 2RSJEM	3354-193-00	1
G17	Idler Pinion Shaft	3354-121-00	1
G18	Woodruff Key #406	2157-000-00	1
G19	Internal Spur Gear	2149-000-00	1
G20	Input Pinion (3/4 keyed engine)	3354-122-00	1
G20	Input Pinion (5/8 keyed 56C motor)	3354-123-00	1
G21	1/4x1 Dowel Pin	1717-002-00	1
G22	Gasket	3354-300-00	1
G23	Oil Lip Seal 1.25x1.75x0.25	2148-000-00	1
G24	Oil Lip Seal 40x62x8	2148-001-00	1
G25	O-Ring- Buna #143	2181-005-00	1
G26	Adapter (engine)	3354-093-01	1
G26	Adapter (56C motor)	3354-092-01	1
G27	5/16-18x3/4 Hex Flange Screw	1745-002-00	4
G28	Assembled Gearbox for Gas Engine Models (includes Ref. Nos. G1 thru G24)	3354-402-90	1
G28	Assembled Gearbox for Electric Models (includes Ref. Nos. G1 thru G24)	3354-403-90	1

Mudsucker Trash Pump

Please provide following information:

-Model Number

-Serial Number (if any)

Part description and number as shown in parts list

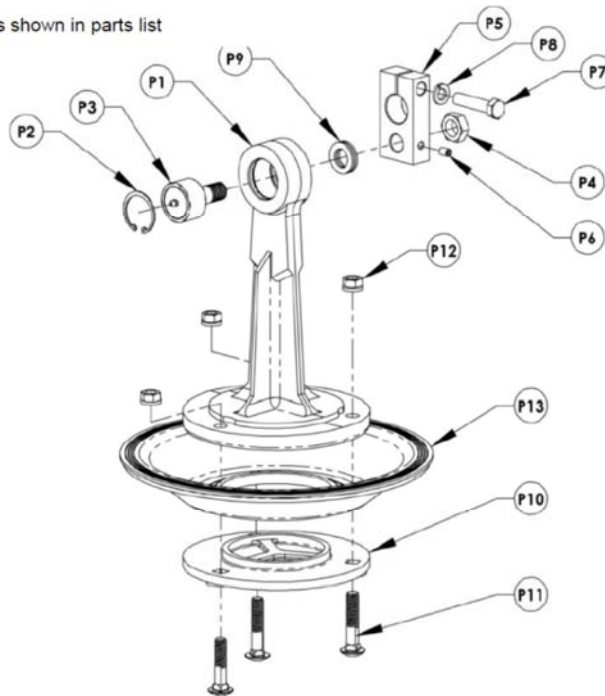

Plunger Assembly – Figure P

Mudsucker Trash Pump

Repair Parts List - Plunger Assembly

Ref. No.	Description	3" Pumps Part Number
P1	Plunger	2134-000-01
P2	Retaining Ring	3350-190-00
P3	Plunger Bearing (includes Ref. No. P4)	2138-000-90
P4	Bearing Lock Nut	Incl. w/P3
P5	Crank Assembly Kit (includes Ref. Nos. P6, P7, P8, P9)	2140-000-90
P6	5/16-18x1/2 Socket Set Screw	Incl. w/P5
P7	1/2-13 Hex Head Cap Screw Grade-5	Incl. w/P5
P8	1/2 Lock Washer	Incl. w/P5
P9	Bearing Shim	Incl. w/P5
P10	Diaphragm Retaining Plate	2133-000-00
P11	Carriage Bolt Kit	3350-011-90
P12	1/2-13 Hex Nut	1782-001-00
P12	3/8-16 Hex Nut	N/A
P13	Diaphragm (Santoprene)	2132-000-00

Mudsucker Trash Pump

Please provide following information:

-Model Number

-Serial Number (if any)

Part description and number as shown in parts list

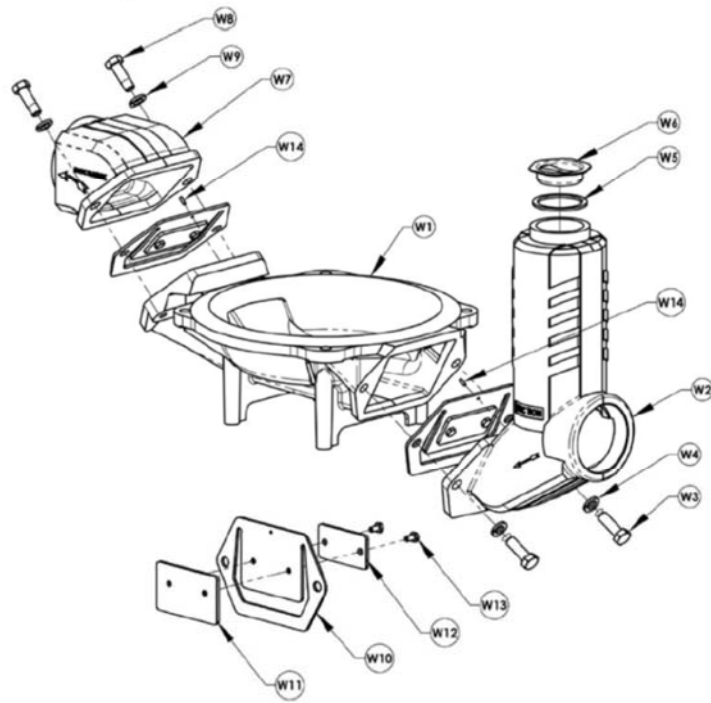

Well Assembly – Figure W

Mudsucker Trash Pump

Repair Parts List - Well Assembly

Ref. No.	Description	3" Pumps Part Number	Qty.
W1	Well	2120-001-00	1
W2	Suction Plate	2123-000-01	1
W3	1/2-13x1-1/2 Hex Head Cap Screw Grade-5	1766-013-00	2
W3	3/8-16x1-1/2 Hex Head Cap Screw Grade-5	N/A	-
W4	1/2 Lock Washer	1798-001-00	2
W4	3/8 Lock Washer	N/A	-
W5	Gasket	2125-000-00	1
W6	Cap	2124-000-00	1
W7	Discharge Plate	2131-000-01	1
W8	1/2-13x1-1/2 Hex Head Cap Screw Grade-5	1766-013-00	2
W8	3/8-16x1-1/2 Hex Head Cap Screw Grade-5	N/A	-
W9	1/2 Lock Washer	1798-001-00	2
W9	3/8 Lock Washer	N/A	-
W10	Check Valve (neoprene)	Incl. w/W15	2
W11	Check Valve Weight Top	Incl. w/W15	2
W12	Check Valve Weight Bottom	Incl. w/W15	2
W13	1/4-20x1/2 Hex Head Cap Screw	Incl. w/W15	4
W14	1/8 diameter x 3/8 Pin	2121-000-00	2
W15	Flapper Valve Assembly Kit (includes Ref. Nos. W10, W11, W12, W13)	3354-071-90	2
W16	Suction Strainer (not shown)	1680-000-00	1

Mudsucker Trash Pump



Wheeler - Rex ■ Ashtabula, Ohio
Tel: 800-321-7950 440-998-2788
Fax: 440-992-2925
wheeler@wheelerrex.com
www.wheelerrex.com
