

Wheeler-Rex Fire Hose Testers

Model 363040



Designed to quickly and safely test fire hose lines !!

- 3 gpm / 500 psi
- One - 2-1/2" NST Swivel female quick fill inlet
- Four - 2-1/2" NST male outlets with individual ball valves
- 115V, single-phase
- Meets testing standards as set forth in the NFPA
- Liquid-filled gauge
- Can test multiple or single hoses - independently controlled
- 1hp electric capacitor motor
- Cage mounted on swivel casters
- Weight - 145lbs

Model 363020



- 3 gpm / 500 psi
- One - 2-1/2" NST Swivel female quick fill inlet
- Two - 2-1/2" NST male outlets with individual ball valves
- 115V, single-phase
- Meets testing standards as set forth in the NFPA
- Liquid-filled gauge
- Can test one or two hoses independently
- 1hp capacitor motor
- Cage Mounted on swivel casters
- Weight - 128lbs

Wheeler - Rex • Ashtabula, Ohio
Tel: 800-321-7950 • Fax: 440-992-2925
wheeler@wheelerrex.com • www.wheelerrex.com



WHEELER-REX
MANUFACTURER'S OPERATING INSTRUCTIONS
FIRE HOSE TESTER MODELS 363040 / 363020

<u>COMPONENTS</u>	<u>DESCRIPTION</u>
Motor	1 HP 60HZ, TEFC 115/230V, 13.6/6.8 FLA, Single Phase
Pump	3 GPM/500 PSI (10 lpm/35 bar) Piston Pump
Gauge	Stainless Steel Liquid-Filled
Inlet	Inlet 2 ½" NST Female Swivel Coupling
Outlet (s)	4 independent ball valves with 2-½" NST Male couplings (363040) 2 independent ball valves with 2-½" NST Male couplings (363040)
Pressure Regulator	Manual-Operated Pressure Relief Valve, adjustable settings with bypass

READ FIRST:

Hose testers should be used by competent, trained personnel within the prescribed guidelines, as set forth by the manufacture and NFPA. Failure of a hose tester under pressure may cause serious bodily injury or property damage. For safety reasons, Wheeler-Rex strongly urges that hoses being tested should be tied together. This will minimize the chance of injury should a hose burst.

HOOKING UP THE PUMP:

1. Connect 2-1/2" NST female swivel inlet to water supply source.
2. Connect fire hose to be tested to suitable adapters on manifold outlets. Hose should have bleed caps or nozzles (per NFPA 7.6.2.2) on the end to bleed the air from the lines at full flow. Hoses should be lying up hill from the pump if possible, and tied together (per NFPA 7.7.3.2).
3. ASSURE MOTOR IS "OFF". Connect the power cord to a standard wall outlet. **Extension cord: when needed, a 12 gauge 3 wire, max 25 ft length, plugged into a 20amp breaker is required.**

OPERATING THE PUMP:

1. Close all outlet ball valves.
2. Open inlet ball valve.
3. Open outlet ball valves one at a time starting with the bottom two first, and allow each hose to be filled completely through manifold. Do not turn pump on at this time.
4. To insure air is safely bled from hoses, bleed each hose, one line at a time with hydrant volume and pressure, utilizing a nozzle or bleed cap at the end of the hose.
5. When each line is filled, free of air, with nozzle closed, close the ball valve at the manifold outlet to seal that line. Even if you are not using all four outlets, bleed them with full hydrant flow. All air must be removed.
6. Slowly, close all outlet valves, & inlet valve
7. Turn the pump on.

Wheeler - Rex • Ashtabula, Ohio
Tel: 800-321-7950 • Fax: 440-992-2925
wheeler@wheelerrex.com • www.wheelerrex.com



7. Check the gauge to verify pressure setting of relief valve. The pressure regulator has been preset at the factory to 500 PSI (Maximum pump capacity). ***To change this setting you must make this adjustment while the under pressure.*** (Under pressure is all 1 ½" ball valves being in the closed position.) To adjust pressure, first loosen the locknut. (It may take only a few turns to make the necessary adjustment.) Turn the T-handle/knob clockwise to increase and counter-clockwise to decrease the pressure. Once desired setting is reached, **IT IS VERY IMPORTANT THAT YOU RE-TIGHTEN THE LOCK/JAM NUT**, do not leave adjustment handle free to move or vibrate out of setting.
8. One at a time **slowly** open the 1 1/2" ball valves the outlets and begin building pressure in all the lines. It may be necessary to open the bleeder valve located at the end of the hose to remove any remaining air. To do this, adjust pressure to 70 PSI or below. Slowly open and close bleeder valve on end of line, one line at a time. In the event there is an acceptable leak in the system that must be overcome by leaving the pump running.
9. If the air has been bled as outlined, the pump will build pressure quickly and safely with only hose stretch to overcome. If a hose ruptures, the only volume of water available is through GPM of pump. NO SURGE OF VOLUME, NO WILD LINE.
10. Remember it is very important to bleed the air out of each line, the manifold and the high pressure side of the pump with as much volume at hydrant pressure as possible. This will provide the most safety during testing.
11. It is impossible to insure that air is not caught behind couplings. If air is caught behind a coupling that fails- it could cause an explosion and fragmentary effect. Do not bend over the top of the pump. Treat hoses and couplings under pressure as dangerous.

MAINTENANCE, TROUBLESHOOTING, AND CAUTIONS:

1. Do not run pump dry. (except for 3-5 seconds when draining)
2. Drain entire system after each use.
3. Flush with anti-freeze to protect from freezing in cold climates.
4. Plug in directly to wall outlet **OR NO SMALLER THAN A 12 GAUGE 3 WIRE 25' EXTENSION CORD.**

POSSIBLE CAUSE

Leaks

Kinked/Collapsed

Pump Sucking Air

Relief Valve Setting

AIR, AIR, AND MORE AIR

Not building pressure

Faulty Gauge

Piston Pump

Motor will not Run

SOLUTION

Look for leaks in water supply or connections.

Supply hose may be kinked or collapsed.

Small holes in supply hose are hard to find as air is sucked inward. Replace supply hose.

500 PSI maximum setting.

Ensure air is bled from hoses, manifold, piping. The length of time to build pressure and test hoses is directly related to overcoming air buildup.

Inlet ball valve has not been closed.

Replace gauge.

Worn seals or cups rebuild pump.

Verify plugged directly into wall outlet, or using a minimum 12 gauge 3 wire, maximum 25' extension cord. Push thermal overload button to reset.

Wheeler - Rex • Ashtabula, Ohio
Tel: 800-321-7950 • Fax: 440-992-2925
wheeler@wheelerrex.com • www.wheelerrex.com



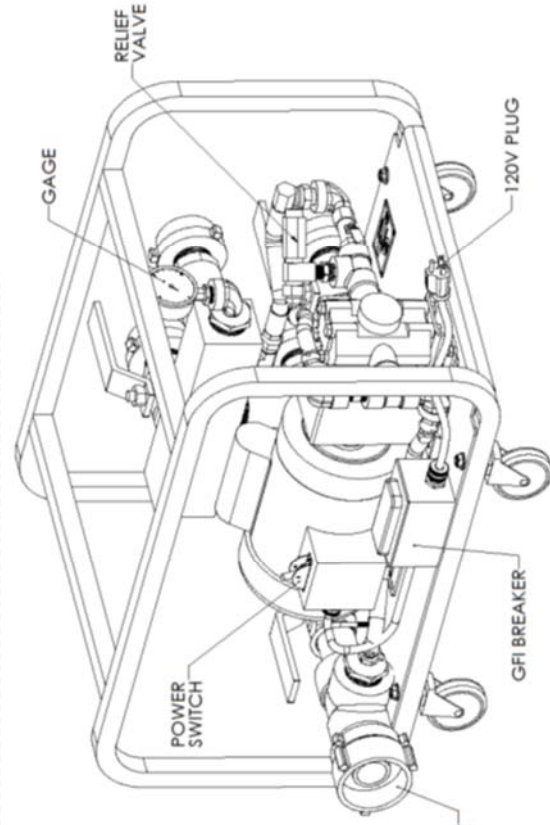
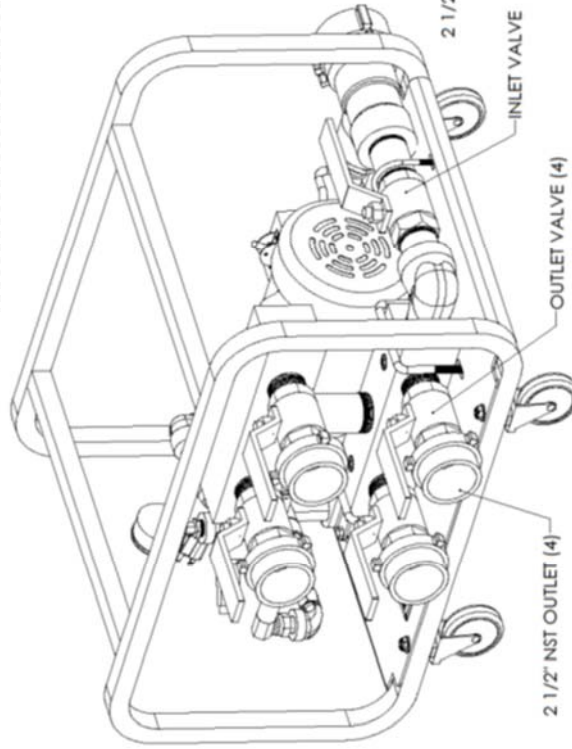
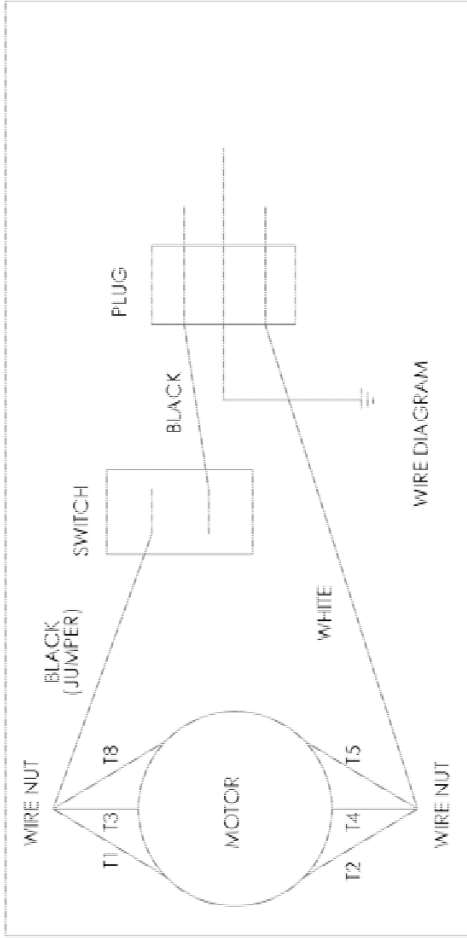



363020
Fire Hose Tester

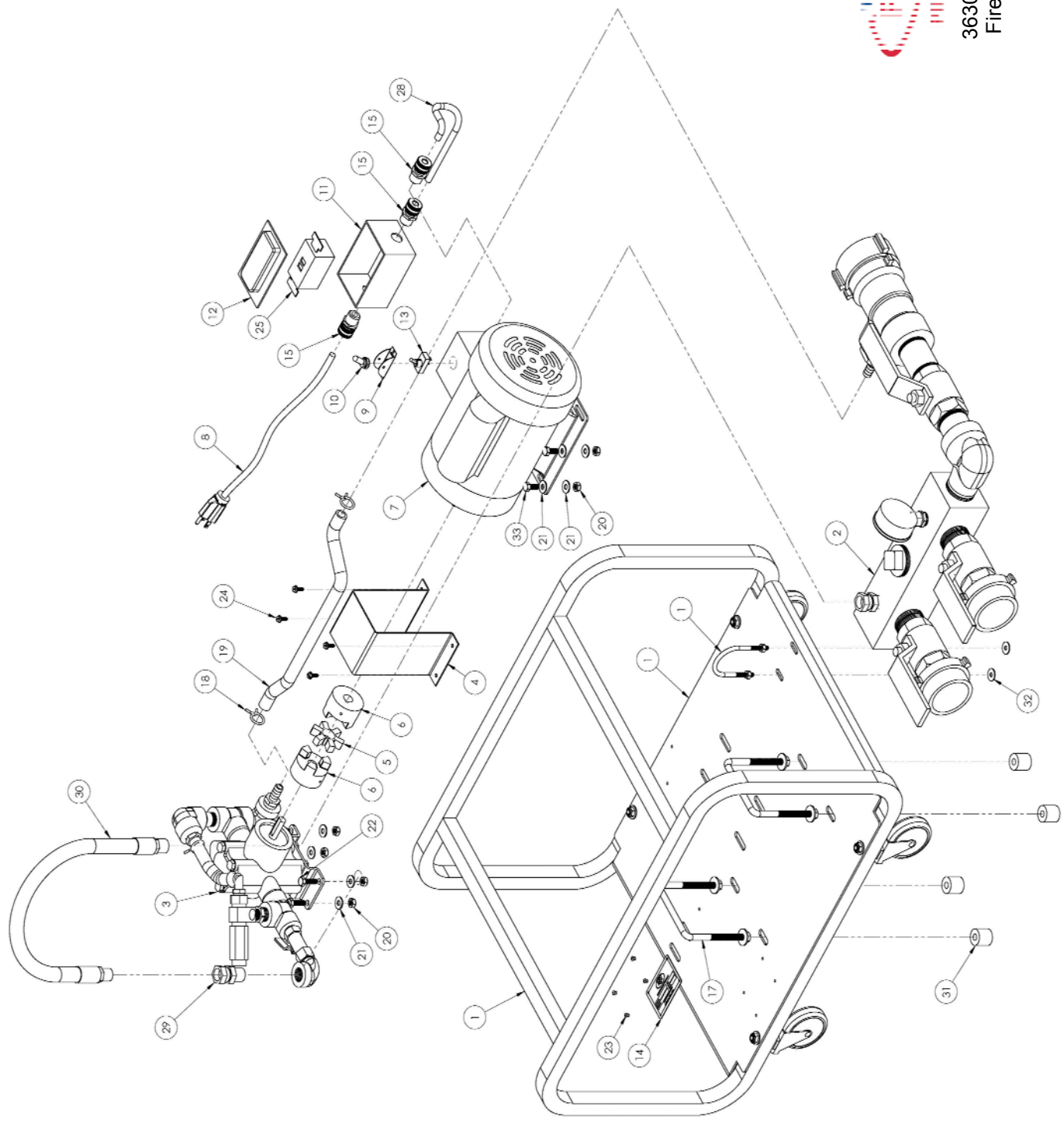

Item	Part No	Description	Qty
1	701177	CAGE & PLATE ASSEMBLY	1
2	701179	MANIFOLD ASSEMBLY-2 HOSE	1
3	701180	PUMP ASSEMBLY	1
4	221306	COUPLING GUARD	1
5	36334	CENTER DISK	1
6	36353	5/8" LOVE-JOY COUPLING HALF	2
7	276351	MOTOR	1
8	221389	CORD SET	1
9	276362	SWITCH GUARD	1
10	276363	SWITCH BOOT	1
11	275881	WEATHERPROOF BOX	1
12	276602	COVER	1
13	276143	SWITCH	1
14	220874	NAME PLATE	1
15	275716	CORD CONNECTOR	3
16	277056	U-BOLT	1
17	277057	SQUARE BEND U-BOLT	2
18	276185	HOSE CLAMP	2
19	701182	SUPPLY HOSE	1
20	275857	5/16-18 HEX NYLON INSERT LOCKNUTS	8
21	275685	5/16" FLAT WASHER	12
22	1020	5/16-18 x 1" HEX HEAD CAP SCREW	4
23	275543	POP RIVET, STAR 4-2AAD	4
24	275427	#10-24 x 5/8" SLTD HX WSHR HD, TYPE F	4
25	276600	GFCI BREAKER	1
26	275471	RING TERMINAL ***NOT SHOWN***	7
27	276601	WIRE NUT ***NOT SHOWN***	2
29	275689	1/2 NPT x 1/2 SWIVEL ADAPTER	1
30	700641	HIGH PRESSURE HOSE	1
31	700892	SPACER	4
32	276540	1/4" FLAT WASHER	2
33	166	5/16-18 x 3/4 HEX HEAD CAP SCREW	4

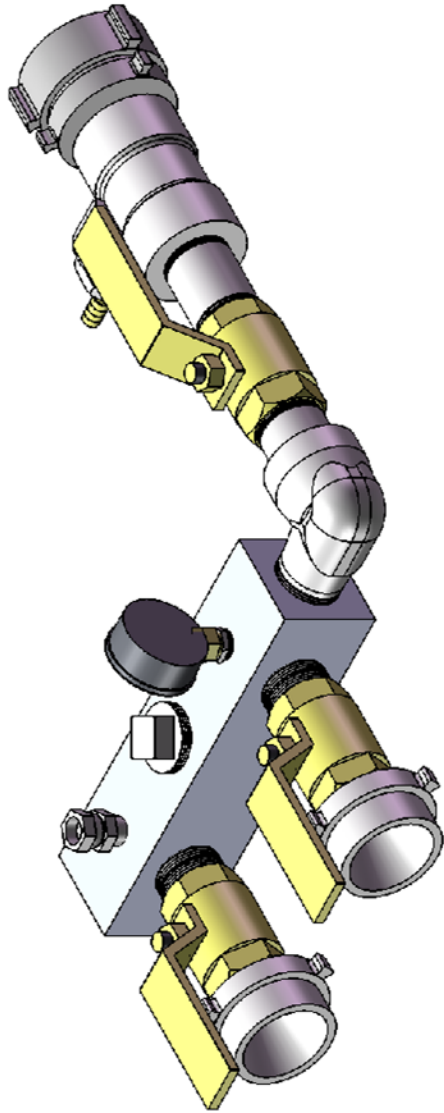

ITEM NO.	PART NUMBER	DESCRIPTION	QTY.
1	701174	MANIFOLD	1
2	276614	1 1/2" FS BLK STREET ELL	1
3	276595	1 1/2" BRZ BALL VALVE	3
4	277051	NPT TO NST HOSE ADAPTER	2
5	276612	1 1/2" x CLOSE Pipe Nipple	2
6	275788	GAGE 0-1000 PSI	1
7	276613	1 1/2" x 3" Pipe Nipple	1
8	276611	1 1/2" FS TEE	1
9	276609	1 1/2" x 1/2" REDUCER BUSHING	1
10	275496	1/2" HOSE BARB	1
11	275670	1/2 x 1/4 FS SCR RD HX BUSH	1
12	276608	1 1/2 PLUG	1
13	277052	NPT TO NST HOSE ADAPTER	1
14	275689	1/2 NPT x 1/2 SWIVEL ADAPTER	1
15	276313	HYD 90 ELL 1/2 NPT x 1/2	1
16	277083	1 1/2" x 4" XH Pipe Nipple	1

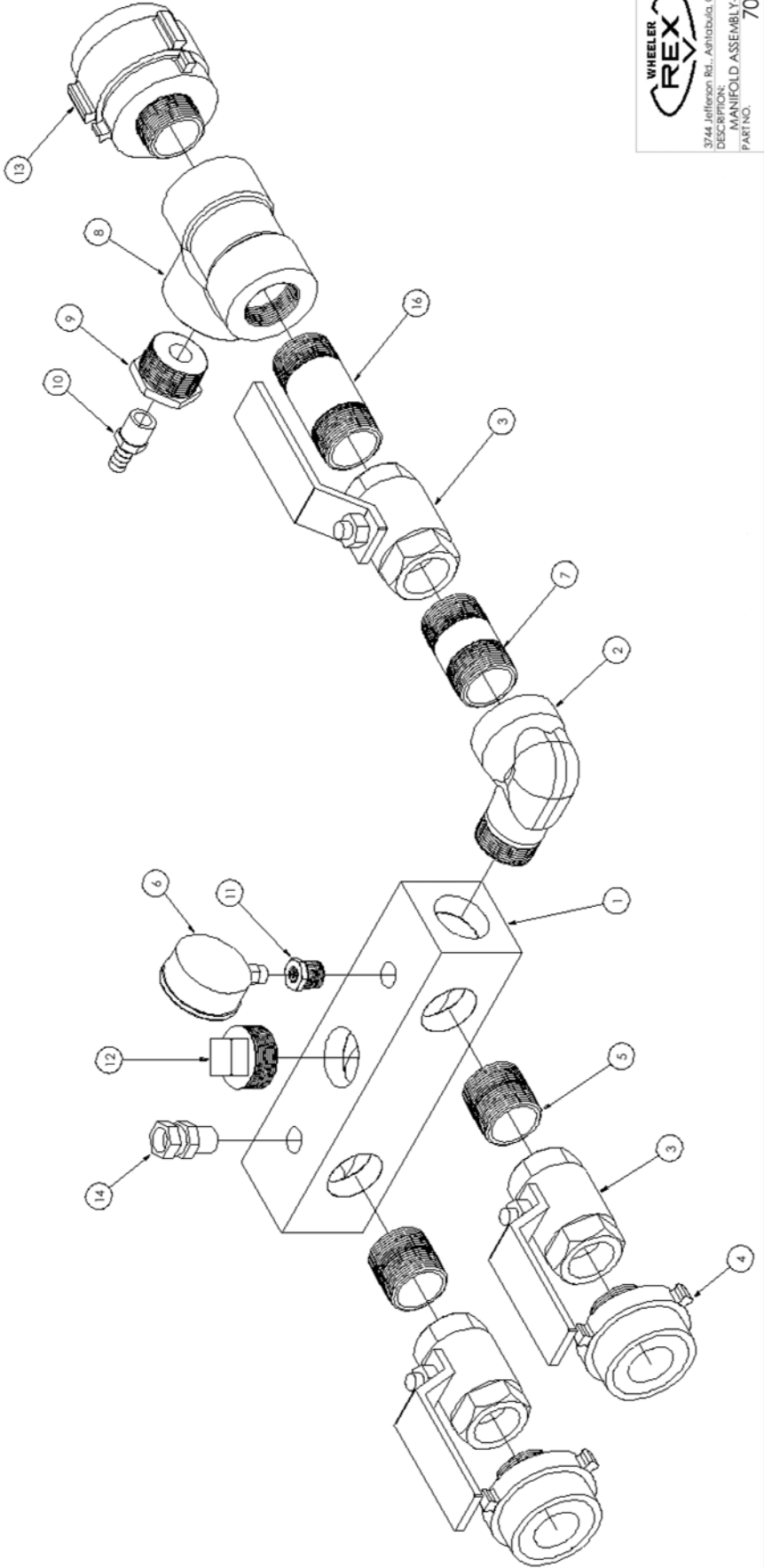

3744 Jefferson Rd., Ashtole, OH 44005
 DESCRIPTION: MANIFOLD ASSEMBLY-2 HOSE
 PART NO. 701179



PUMP ASSEMBLY
PART NO. 701180

ITEM NO.	PART NUMBER	DESCRIPTION	QTY.
1	276337	PISTON PUMP	1
2	275669	1/2 X CLOSE PIPE NIPPLE	3
3	275667	1/2" 2000LB FS SCRD TEE	2
4	275496	1/2" HOSE BARB	2
5	275697	1/2" 3000LB FS SCRD 90 ELL	1
6	275633	1/2 X 2" XH Pipe Nipple	1
7	275666	1/2" FS SCRD STREET ELL	2
8	275675	1/2" VALVE	1
9	276185	HOSE CLAMP	2
10	276144	RELIEF VALVE	1
11	276186	3/8 NPTX 1/2 90 deg. HOSE BARB	1
12	276722	1/2 X 3/8 BUSHING	1
13	275966	3/8 Close Street Nipple	1
14	700343	BYPASS HOSE	1

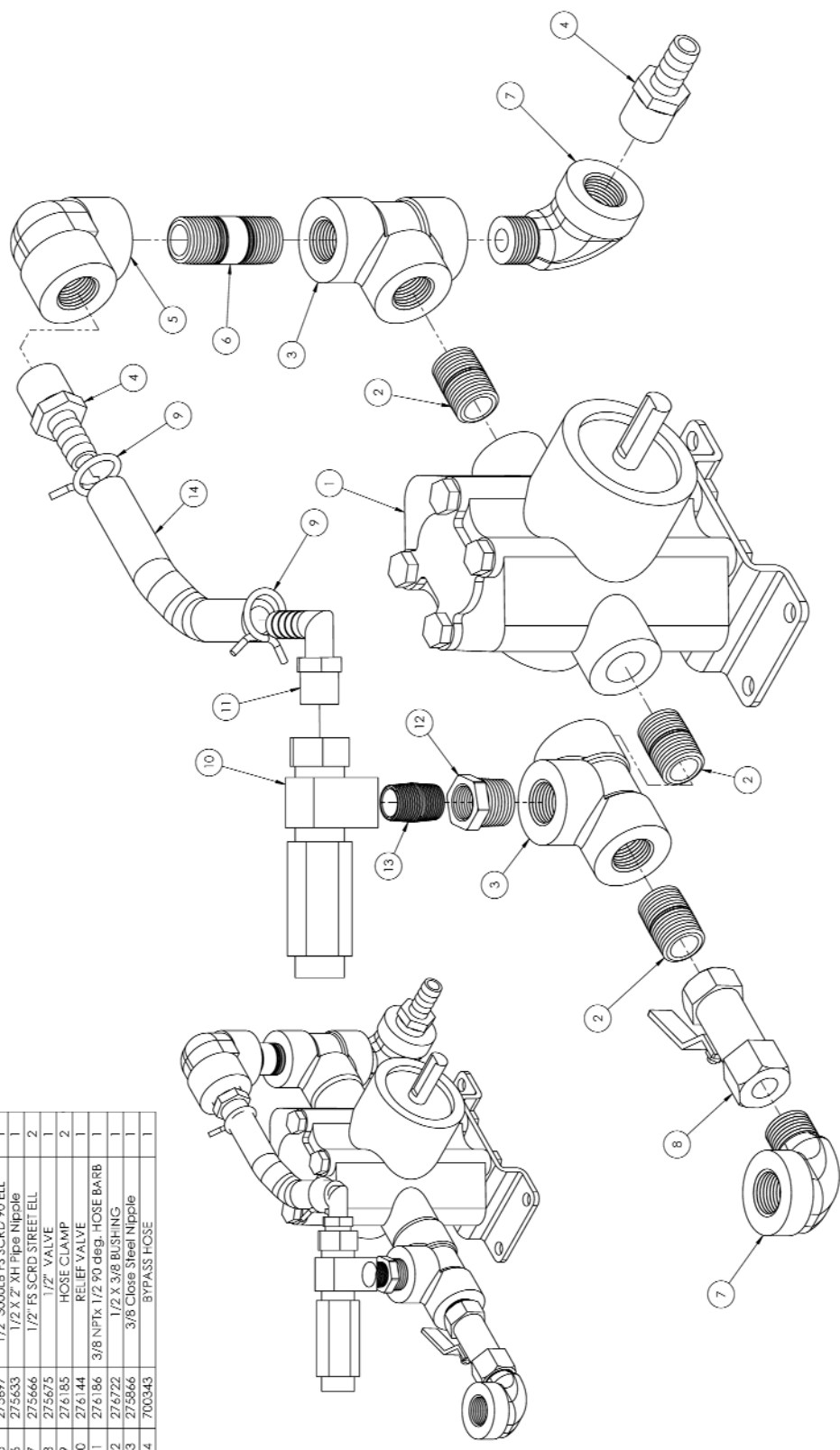

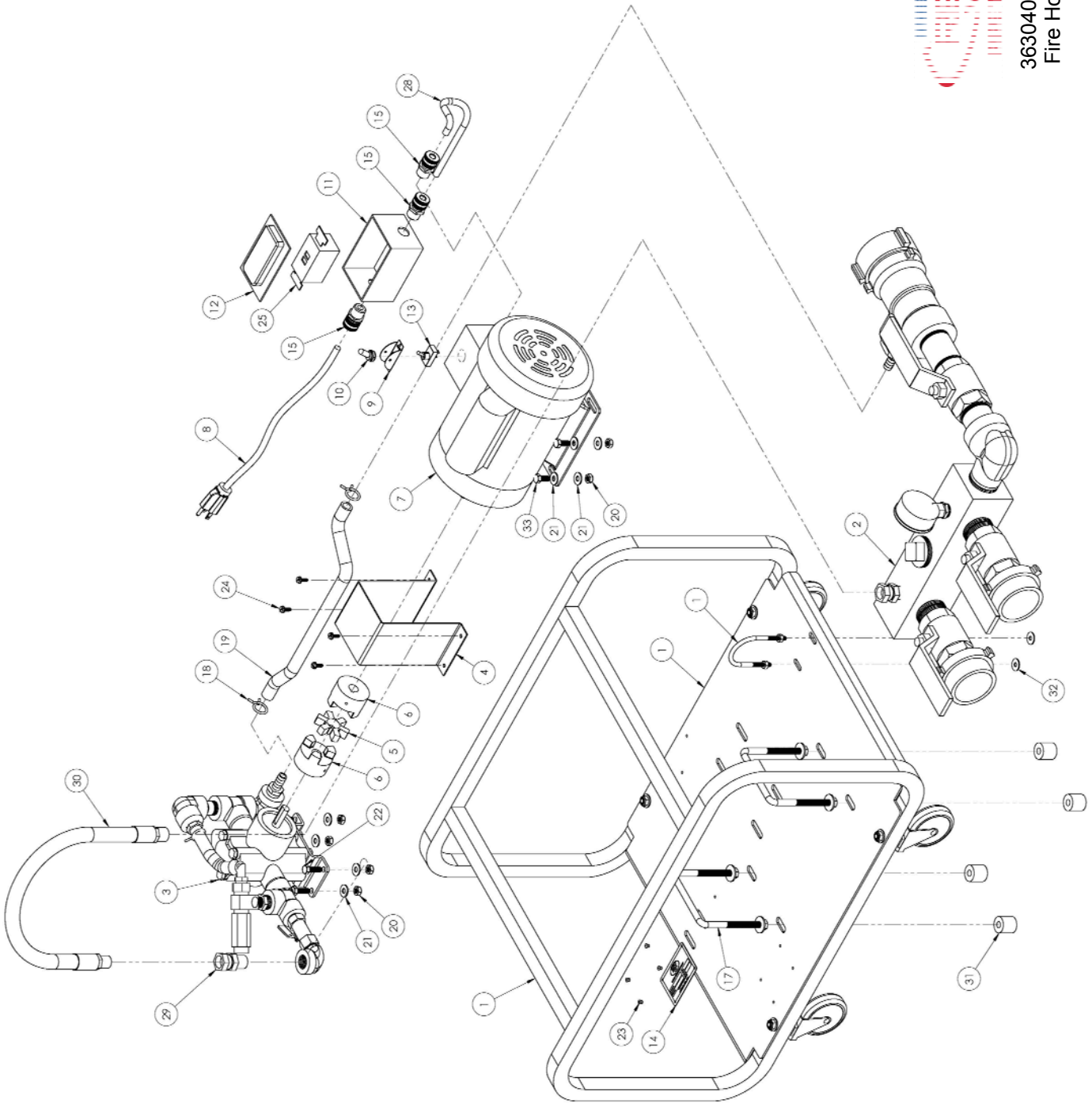

363040
Fire Hose Tester

Item	Part No	Description	Qty
1	701177	CAGE & PLATE ASSEMBLY	1
2	701178	MANIFOLD ASSEMBLY	1
3	701180	PUMP ASSEMBLY	1
4	221306	COUPLING GUARD	1
5	36334	CENTER DISK	1
6	36353	5/8" LOVE-JOY COUPLING HALF	2
7	276351	MOTOR	1
8	221389	CORD SET	1
9	276362	SWITCH GUARD	1
10	276363	SWITCH BOOT	1
11	275881	WEATHERPROOF BOX	1
12	276602	COVER	1
13	276143	SWITCH	1
14	220874	NAME PLATE	1
15	275716	CORD CONNECTOR	3
16	277056	U-BOLT	1
17	277057	SQUARE BEND UBOLT	2
18	276185	HOSE CLAMP	2
19	701182	SUPPLY HOSE	1
20	275857	5/16-18 HEX NYLON INSERT LOCKNUTS	12
21	275685	5/16" FLAT WASHER	12
22	1020	5/16-18 x 1" HEX HEAD CAP SCREW	4
23	275543	POP RIVET, STAR 4-2AAD	4
24	275427	#10-24 x 5/8" SLTD HX WSHR HD, TYPE F	4
25	276600	GFCI BREAKER	1
26	275471	RING TERMINAL ***NOT SHOWN***	7
27	276601	WIRE NUT ***NOT SHOWN***	2
29	700892	SPACER	4
30	276540	1/4" FLAT WASHER	2
31	166	5/16-18 x 3/4 HEX HEAD CAP SCREW	4
32	700326	PRESSURE HOSE 12.5" LONG	1

ITEM NO.	PART NUMBER	DESCRIPTION	QTY.
1	701174	MANFOLD	2
2	276595	1 1/2" BRZ BALL VALVE	5
3	277051	NPT TO NST HOSE ADAPTER	4
4	276612	1 1/2" x CLOSE Pipe Nipple	4
5	277054	1 1/2" x 5" XH Pipe Nipple	1
6	275666	1/2" FS SCRD STREET ELL	1
7	275788	GAGE 0-1000 PSI	1
8	275368	HEX SOCKET 1/2" NPT PIPE PLUG	3
9	276609	1 1/2" x 1/2" REDUCER BUSHING	2
10	276313	HYD 90 ELL 1/2" NPT x 1/2"	1
11	275670	1/2" x 1/4" FS SCRD HX BUSH	1
12	276614	1 1/2" FS BLK STREET ELL	1
13	276613	1 1/2" x 3" Pipe Nipple	1
14	276611	1 1/2" FS TEE	1
15	275496	1 1/2" HOSE BARB	1
16	277052	NPT TO NST HOSE ADAPTER	1
17	277083	1 1/2" x 4" XH Pipe Nipple	1

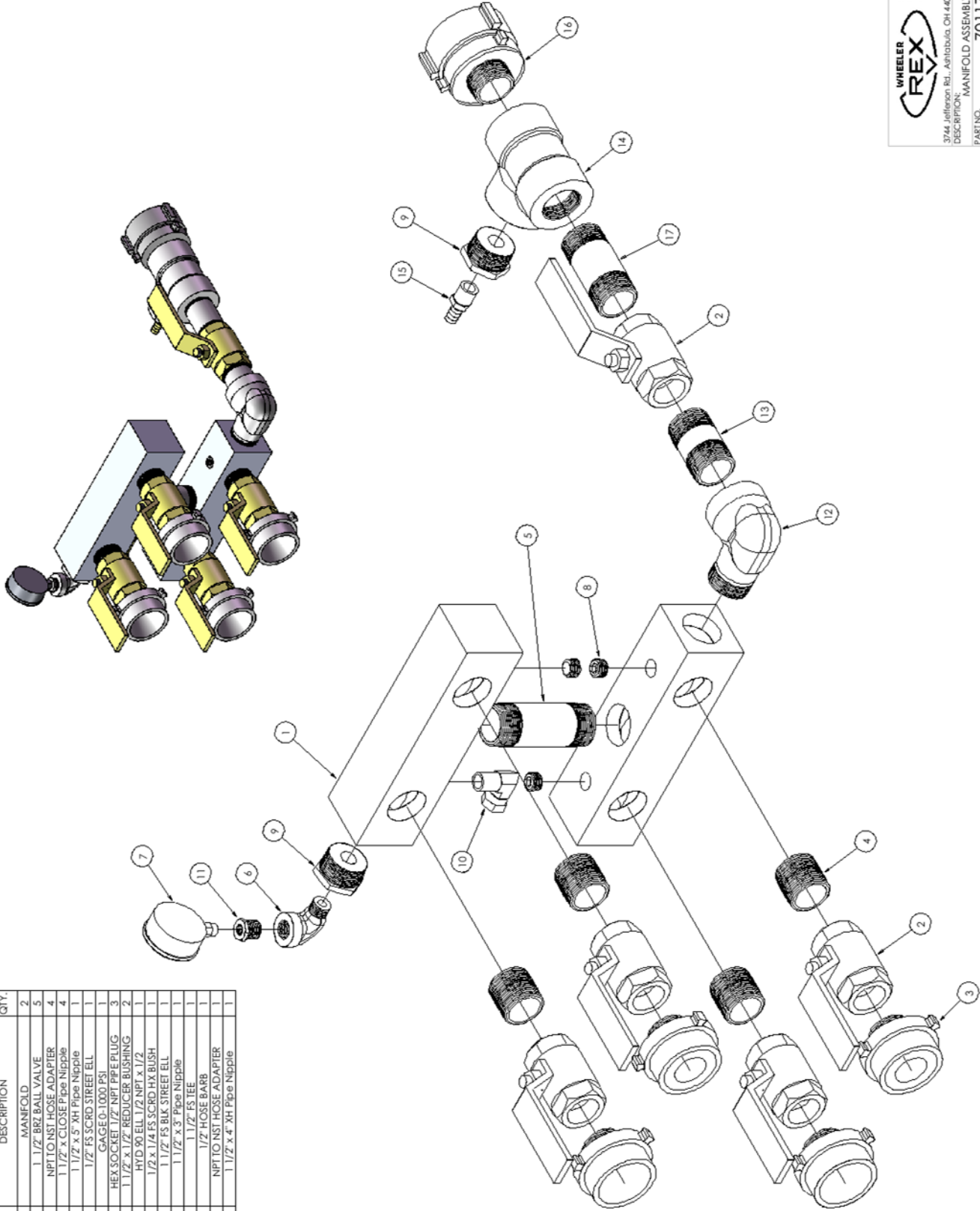

 3744 Jefferson Rd., Ashland, OH 44805
 DESCRIPTION: MANIFOLD ASSEMBLY
 PART NO. 701178



WHEELER-REX LIMITED LIFETIME WARRANTY

WHEELER-REX covers its products with a Limited Lifetime Warranty, with exception of pipe threading machines which have a Limited Three Year Warranty (including electric motors). Warranties from manufacturers of components used in our products may pre-empt the Wheeler-Rex warranty. Wheeler-Rex warranties against defects in material or workmanship. To take advantage of this warranty, the complete product must be delivered prepaid to Wheeler-Rex or any WHEELER-REX AUTHORIZED SERVICE CENTER. No tools are to be returned to the factory without receiving prior authorization. Obviously, failures due to misuse, abuse, or normal wear and tear are not covered by this warranty. **NO OTHER WARRANTY, WRITTEN, OR ORAL, APPLIES. THERE ARE NO WARRANTIES WHICH EXTEND BEYOND THE DESCRIPTION ON THE FACE HEREOF.** No employee, agent, dealer, or other person is authorized to give any warranty on behalf of Wheeler-Rex. Warranted products will be repaired or replaced at our option, at no charge and returned to you via prepaid transportation. Such replacement or repair is the exclusive remedy available from Wheeler-Rex. Wheeler-Rex is not liable for damage of any sort, including incidental and consequential damages. Some U.S.A. states do not allow the exclusion or limitation of incidental or consequential damages, so the above limitation or exclusion may not apply. This warranty gives you specific legal rights, and you may also have other rights which vary from state to state.

Form # 1031

WARNING

GENERAL TOOL OPERATION WARNINGS

FOR ALL TOOLS-

1. **Keep Guards in Place** and in working order.
2. **Remove Adjusting Keys and Wrenches** from tool before turning it on.
3. **Keep Work Area Clean.** Cluttered areas and benches invite accidents.
4. **Avoid Dangerous Environment.** Don't use power tools in damp or wet locations. Keep work area well lit. Don't expose power tools to rain.
5. **If you must use an electric tool in a damp or wet location;** make sure it is plugged into a circuit which is protected by a ground fault interrupt.
6. **Keep Children Away. ALL VISITORS SHOULD BE KEPT A SAFE DISTANCE FROM WORK AREA.**
7. **Store Idle Tools** in dry, high, or locked-up place out of reach of children.
8. **Don't Force Tool.** It will do a better and safer job at the rate for which it is designed.
9. **Use Right Tool.** Don't force a small tool or attachment to do the job of a heavy-duty tool.
10. **Wear Proper Apparel.** No loose clothing or jewelry to get caught in moving parts. Rubber gloves and footwear are recommended when working outdoors.
11. **Use Safety Glasses.**
12. **Don't Abuse Cord.** Never carry tool by cord or yank it to disconnect from receptacle. Keep cord from heat, oil, and sharp edges.
13. **Secure Work.** Use clamps or vise to hold work when practical. It's safer than using your hand and it frees both hands to operate tool.
14. **Don't Overreach.** Keep proper footing and balance at all times.
15. **Maintain Tools Properly.** Keep tools sharp and clean for best and safest performance. Follow instructions for lubricating and changing accessories. Equipment operators must have proper maintenance & instruction sheets. Be sure the tool operator reads and understands this information. If you don't have current maintenance and instruction sheets, contact the factory & we will supply them at no charge.
16. **Disconnect Tools** when not in use; before servicing; when changing accessories such as dies, cutters, etc.
17. **Avoid Accidental Starting.** Don't carry plugged-in tool with finger on switch. Be sure switch is off when plugging in.
18. **Outdoor Use Extension Cords.** When tool is used outdoors, use only extension cords suitable for use outdoors and so marked.
19. **Wear Ear Protection** if exposed to long periods of very noisy shop operations.
20. **Do not operate tools** while under the influence of alcohol, drugs or medication.

Wheeler - Rex • Ashtabula, Ohio
Tel: 800-321-7950 • Fax: 440-992-2925
wheeler@wheelerrex.com • www.wheelerrex.com

