

50/60 Hz



PIPE THREADING MACHINE

8991

OPERATION MANUAL

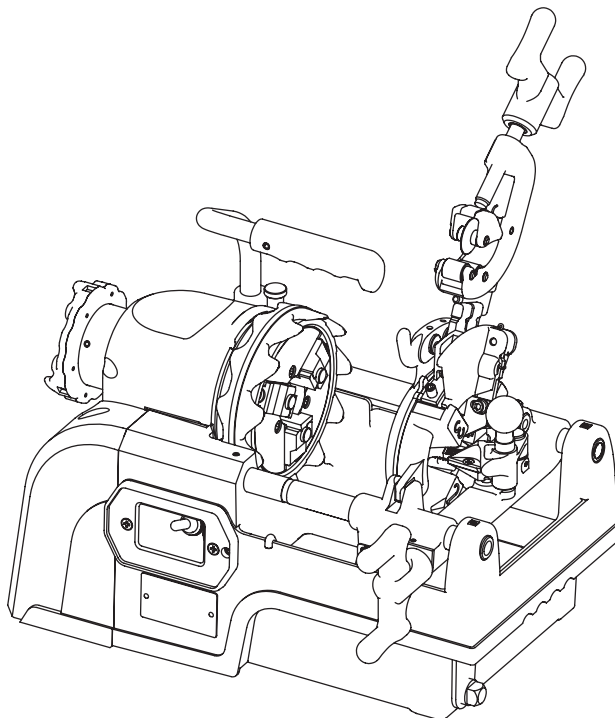

Be sure to read this operation manual before using the machine.

Note

- Be sure to hand this operation manual to the user.
- Be sure to keep the manual where the operator can refer to it whenever necessary.
- To ensure safe and efficient use, read the manual thoroughly before using the machine.

Date of Purchase: Year

Month

Distributor:

Thank you for purchasing a WHEELER-REX pipe threading machine.

Our product will give you years of high-precision processing and reliable service if you simply follow the instructions in this manual carefully.

- To prevent accidents such as fire, electric shock, injury etc., please be sure to observe the Safety Considerations and Precautions when using 8991.
- Before using the product, therefore, make sure you read the manual from start to finish, paying particular attention to the Safety Considerations and Precautions.
- To avoid accident and injury, never use the machine for any purposes other than those described in this manual. Should you need further advice, contact your distributor or WHEELER-REX.

CONTENTS

Safety Considerations	1
Precautions when using 8991	2
Main Parts, Standard Specifications, Accessories, Options, and Their Applications	5
Getting Ready / Operation Guide	
1. Transportation	6
2. Setting up	6
3. Cutting oil	6
4. Attaching and removing the die head	6
5. Self-opening Die head	7
6. Manual-open Die head	9
7. Setting Up the Pipe / Removing the pipe	10
8. Power supply.....	10
9. Checks before starting	11
10. Motor with braking system	11
11. Cutting pipes	12
12. Reaming.....	13
13. Carriage collision prevention mechanism	13
14. Improper use of a pipe wrench	13
15. Cutting threads (Self-opening Die Head)	14
16. Cutting threads (Manual-open Die Head)	15
17. Measuring threads with a gauge	16
Daily Inspection, Maintenance	17
Requesting Repairs	18
Servicing and Repairs, Troubleshooting	19

Definitions of WARNING and CAUTION

In this operation manual, warnings are divided into **WARNING** and **CAUTION**.

WARNING: indicates actions that could possibly result in death or severe injury to the user if the machine is used incorrectly.

CAUTION: indicates actions that could possibly result in injury to the user, or physical damage, if the machine is used incorrectly.

Even items marked **CAUTION** could have serious outcomes under certain conditions.

Be sure to observe these warnings carefully as they greatly affect safety.

- If this manual is lost or damaged, promptly order a replacement from your distributor or WHEELER-REX.
- Parts and specifications are subject to change without prior notice, due to improvements in quality, performance or safety standards. In such cases, the contents, photographs, illustrations, etc. in this manual may be different to the product you have purchased.

SAFETY CONSIDERATIONS

WARNING

1. Ensure you use the correct voltage.

- Be sure to use the voltage indicated on the nameplate on the main unit or in this manual. If the voltage is different from the voltage indicated, overheating, smoke or fire may occur.

2. Check the switch is OFF before inserting the plug into the power supply socket.

- If the plug is inserted into the power supply when the switch is ON, the machine may start up abruptly and is liable to cause accidents. Be sure to check the switch is OFF.

3. Avoid electric shock.

- Never touch the plug with wet hands.
- Do not use the machine in rain or in places where moisture can easily get into the machine.
- Be sure to ground the machine to avoid electric shock.

4. Be aware of the environment you are working in.

- Do not use the machine in the rain, in humid or damp places, or places where moisture can easily get into the machine. Humidity will lower insulation of the motor and cause electric shock.
- Do not use close to flammable fluids or gases, such as gasoline or paint thinner. Doing so might result in fire or explosion.

5. Use designated accessories and attachments.

- Do not use accessories and attachments other than those designated in this manual or our catalogues. Accident or injury might result if you do.

6. In the following cases, turn the unit OFF and pull the plug out of the socket:

- when the machine is not in use or parts are changed, repaired, cleaned or inspected,
- when accessories are changed,
- when hazards are expected (including a power failure),
- when the plug is inserted (the machine may start up unexpectedly, which could cause an accident).

7. If any abnormality is noticed, stop the machine immediately.

- If the machine does not operate smoothly, or abnormalities such as unusual odours, vibration or noise are detected, stop operating the machine immediately.
- Check symptoms against the items listed under "Troubleshooting" at the end of this manual, and follow the corresponding instructions. Continuing to use the machine may result in overheating, smoke or fire, and may cause accident or injury.
- If the unit overheats or produces smoke, do not attempt to overhaul it yourself but ask for an inspection and repair.

8. Keep the work site clean.

- Ensure you keep workbenches and the worksite in good order and well lit. Cluttered worksites and workbenches are liable to cause accidents.

9. Do not let any unauthorised personnel near the machine.

- Do not let anyone other than authorised personnel touch the machine or the power cord, or operate the machine.
- Do not let anyone other than authorised personnel enter the work site, especially children. They could get seriously injured.

10. Do not apply excessive force.

- To ensure safe and efficient operation, use within the capacity of the main unit. Applying force may not only cause damage to the product but could also result in accident or injury.
- Do not use the machine in any way that could cause the motor to lock, or result in smoke or fire.

11. Use the machine only for its designated purpose.

- Do not use the machine on pipes not specified in this manual. Using the machine for any purpose other than threading pipes, such as fastening the pipe to a joint etc., will not only damage the machine and/or motor but could also lead to accident or injury.

12. Wear proper working clothing.

- Do not wear neckties, clothes with open sleeves, loose clothing, accessories such as necklaces, etc. Do up buttons and zippers which could get caught in the rotating parts and result in serious accident or injury.
- When working outdoors, it is recommended that you wear rubber gloves and non-slip shoes. Slippery gloves and shoes are liable to cause injuries. Do not wear scarves and cover long hair with caps or hair nets to prevent them getting caught in rotating parts.
- Wear safety caps, safety shoes, etc. according to the working environment.

13. Do not work in an unnatural posture.

- Keep a firm footing and balance to avoid falling over and injuring yourself.

14. Remove tools such as wrenches.

- Before turning the switch ON, check that any tools used for inspection and adjustment have been removed. If you use the machine when tools are left inside it, accidents and injuries may occur.

SAFETY CONSIDERATIONS

WARNING

15. Operate the unit with great care.

- Always work with great attention to how you handle and operate the machine and the surrounding conditions. Carelessness may result in accident or injury.
- Do not operate the machine when concentration is lowered such as when tired, after drinking alcohol, when sick or affected by medicine, etc.

16. Do not handle the power cord carelessly.

- Do not carry the machine by the cord, or pull the plug out of the socket with the cord.
- Do not place the cord near heated objects, fats and oils, cutters or objects with sharp edges.
- Take care not to tread on the cord, pull it or apply unnecessary force resulting in damage to the cord. Doing so may result in electric shock, or a short-circuit may occur and cause a fire.

17. Perform careful maintenance daily.

- When changing accessories and parts, follow the operation manual.
- Periodically inspect the power supply cord and plug. If damaged, ask your distributor or WHEELER-REX for repairs. If you don't do so, there is a risk of electric shock or short-circuiting and fire.
- If an extension cord is used, inspect the cord periodically and, if damaged, replace it. If extension cords are used outdoors, use extension cords designed for outdoor use to prevent electric shock, short-circuit or fire.
- Keep parts used for gripping the unit with your hands dry and clean, and free of oil and grease. If your hands slip, you may be injured.

18. Check for damaged parts.

- Before using the machine, carefully check for any damage to the protective cover and other parts, and check both normal operation and specified functions.
- Check for any abnormalities such as adjustment of movable parts, tightening, damage to and installation of parts and all parts affecting operation.
- Do not use the machine if it has a damaged power cord or plug. Doing so may cause electric shock or a short circuit leading to fire.
- Do not use the machine if the Stop and Start switches do not work properly.
- When replacing or repairing a broken protective cover and other parts, follow the operation manual. If no instructions are specified in the operation manual, ask your distributor or WHEELER-REX for repairs.

19. Store carefully when the machine is not in use.

- Store in a dry place away from children and locked with a key.

20. For overhaul and repair of the machine, ask an appointed REX agent.

- Our products comply with corresponding safety standards. Do not remodel.
- Be sure to ask your distributor or WHEELER-REX for any repairs. If repairs are carried out by unskilled or unqualified personnel, the performance of the unit will be adversely affected and may result in accident or injury.

WARNING - Proposition 65 -

- This product can expose you to chemicals lead and lead compounds, which are known to the State of California to cause cancer and birth defects or other reproductive harm. For more information go to www.P65Warnings.ca.gov.

PRECAUTIONS WHEN USING 8991

Threading

WARNING

1. Take care when handling the blades.

- To prevent accidents and injuries, take special care when handling blades such as dies, reamers, pipe cutters etc.

2. Do not put your hands or face near rotating parts when the machine is in use.

- You could get caught in rotating parts or hit by scrap, resulting in accident or injury.

3. Do not start on the next job while the machine is still rotating.

- When you turn the switch off, the machine will not stop rotating immediately. Perform the next job only after checking that the machine has come to a complete stop. Failure to do so may result in accident or injury.

4. Do not wear gloves when operating the machine.

- Gloves may get caught in rotating parts or blades, resulting in accident or injury.

5. Do not leave the machine while it is still rotating.

- Others may be injured.

PRECAUTIONS WHEN USING 8991

WARNING

6. If you accidentally drop or hit the machine, carefully check for damage, cracks, deformities or any abnormalities.

- If any abnormalities are found, ask your distributor or WHEELER-REX for an inspection and/or repair.
- Continuing to use the machine when damaged will likely lead to mechanical problems, accident or injury.

7. Do not touch the dies or scrap just after threading.

- The dies and scrap can become very hot just after threading; touching them could burn or injure you.

8. Die head and dies.

- Use the die head and dies that are appropriate for the type and diameter of pipe to be processed.
- When threading stainless steel pipes, use pipes with a wall thickness equivalent to Schedule 40 or more.
- Make sure the die head is mounted correctly on the carriage. Be careful not to get your fingers caught.
- Before you start threading, set the die head in the threading position, switch ON, and check that the oil is flowing correctly over the dies. Failing to do so could result in an imperfect thread, damage to the machine, accident or injury.

9. Be sure to check the starting position before threading.

- When threading, start with the carriage to the right of the red line on the front support bar (as viewed from the working position). If the carriage is not in the correct starting position, the die head will collide against the main unit while threading, causing mechanical problems, accident or injury.

10. Use the pipe support when threading long pipes.

- When threading long pipes, use a pipe support to prevent both vibration due to warping while the pipe is rotating, and instability of the machine due to the weight of the workpiece. If a pipe support is not used, threading cannot be performed correctly and problems with the machine, accident or injury may occur.

11. Be sure to attach accessories according to the operation manual.

- Attaching accessories incorrectly may cause the machine to topple over resulting in accident or injury.

12. Precautions when using the machine with an oil tray.

- If you are going to work with the machine placed in an oil tray, be sure to put the machine on a table and make sure it is not immersed in oil, otherwise the oil might be sucked in resulting in damage to the motor.

Using the pipe cutter

CAUTION

1. When cutting pipes, turn the cutter handle no faster than ½ a rotation for each rotation of the pipe.

- If the cutter handle is turned too quickly when engaging the pipe, it can distort the shape of the pipe and may not make a proper thread.

2. Do not leave the machine unattended while it is still rotating.

- Others may be injured.

WARNING

1. Changing parts with blades, sharp edges, etc.

- To prevent accidents and injury, take special care when handling or changing any parts with sharp edges such as dies, reamers, pipe cutters and carbide cutters.
- Be sure to attach accessories according to the operation manual. Make sure you use only genuine WHEELER-REX accessories. Using any other type can lead to accident and injury, as well as damaging the machine itself.
- Avoid attaching accessories incorrectly as doing so may cause the machine to topple over, resulting in accident or injury.

2. Use a pipe support when threading long pipes.

- When threading long pipes, use a pipe support to prevent both vibration due to warping while the pipe is rotating and instability of the machine due to the weight of the workpiece. If a pipe support is not used, threading cannot be performed correctly; as a result, problems with the machine, accidents or injuries may occur.

3. Do not put your hands or face near rotating parts when the machine is in use.

- You could get caught in rotating parts or hit by scrap, resulting in accident or injury.

4. Do not wear gloves when operating the machine.

- Gloves may get caught in rotating parts or blades etc., resulting in a serious accident or injury.

PRECAUTIONS WHEN USING 8991

Reaming

WARNING

Reamer blades are very sharp; to prevent injury, avoid touching them with bare hands.

Handling thread cutting oil

CAUTION

1. Wear goggles.

- Touching the eyes with oil may cause inflammation.
- Emergency treatment: Wash eyes with clean water for about 15 minutes and seek medical attention.

2. Wear protective gloves.

- If oil comes into contact with the skin, it may cause inflammation.
- Emergency treatment: Carefully wash the affected part with soap and water.

3. Take care not to breathe in oil mist or steam.

- Breathing in oil mist or steam may cause nausea.
- Emergency treatment: Carry the person out into the fresh air, cover them with a blanket, keep them warm and relaxed, and seek medical attention.

4. Do not thin the oil or mix it with threading oil produced by other companies.

5. If water gets mixed in with the threading oil and the colour changes to a milky white or the oil deteriorates excessively resulting in a poor finish, change to fresh oil promptly.

6. Do not drink the oil.

- Drinking the oil may cause diarrhea or vomiting.
- Emergency treatment: Seek medical attention immediately, without forcing the person to vomit.

7. Do not place the oil where it can easily be reached by small children.

8. Be very careful of fire.

9. Storage.

- Always close the lid after use to prevent the oil from being contaminated by dust, water or other foreign bodies.
- Store in a dark place away from direct sunlight.

10. Drums (200L).

- To prevent them from bursting, do not apply pressure to empty drums.
- Do not weld, heat, drill or cut the drums or they may burst into fire from the residue they contain.

WARNING

1. Do not burn off the oil.

- Oil contains chlorine compounds and generates toxic gas when burnt. In the case of an emergency in which someone has inhaled such toxic gases, carry the affected person out into the fresh air and seek medical attention.

2. Handling waste oil and waste cans.

- Handle materials according to local laws and regulations regarding waste disposal and cleaning.
- If uncertain, consult your distributor or WHEELER-REX.

Pipe

CAUTION

1. Do not use highly deformed or damaged pipes as doing so may lead to poor, if not unusable, threads.

2. When threading stainless steel pipes use pipes with a wall thickness equivalent to Schedule 40 or more.

MAIN PARTS, STANDARD SPECIFICATIONS, ACCESSORIES, OPTIONS AND THEIR APPLICATIONS

MAIN PARTS

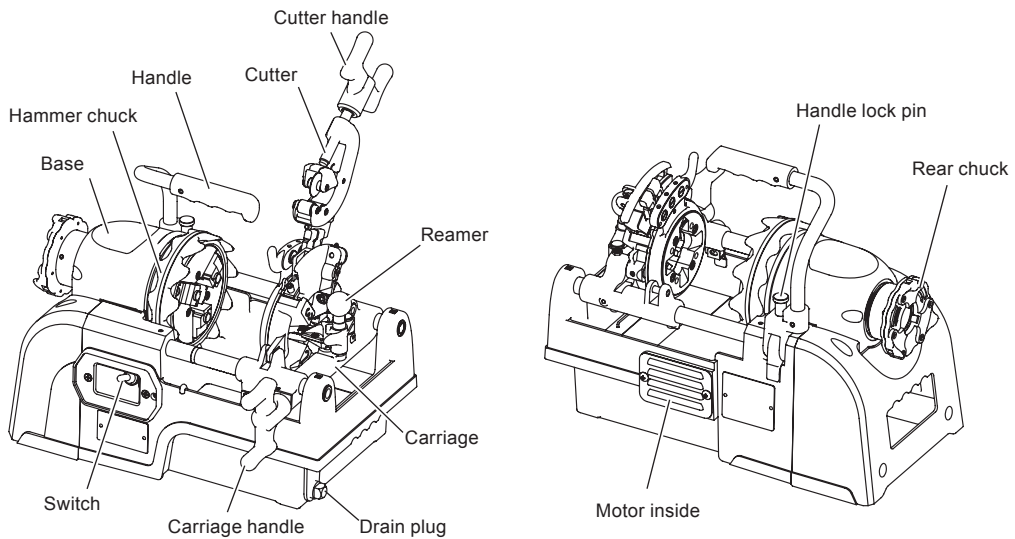

Fig. 1

STANDARD SPECIFICATIONS

Model	No. 8991
Threading capacity	½ B (15A) - 1 B (25A)
Voltage	120 V (50/60 Hz)
Motor single phase	Input 400 W / Output 400 W, series motor (with brake)
Rotation speed	55 r.p.m (unloaded)
Net weight	58 lbs (26.1 kg)
Dimensions	18" x 12.5" x 14" / 450(L) x 320(W) x 350(H) mm

Table 1

STANDARD ACCESSORIES

Model	No. 8991
Die head	Auto ½ - 1" NPT
Dies	(½ - ¾") (1") One set each
Hexagonal keys	3 mm, 5 mm 1 each

Table 2

APPLICATIONS

Cutting, reaming, threading steel and stainless steel pipes.

GETTING READY / OPERATION GUIDE

1. Transportation (Fig. 2)

When moving or transporting the machine, remove the oil pan. There is no need to drain off the cutting oil in the tank.

- (1) Secure the cut end of a pipe firmly with the chuck, fix the pipe in position with the cutter, and move the machine.
- (2) By raising the handle, the lock pin falls into the position, and the handle is secured.

* When lowering the handle, lift the lock pin at the same time.

⚠ CAUTION

- When transporting the machine, please check and confirm that the handle is secured properly.
- Always position the handle as shown in Fig. 2 when cutting threads or performing other similar work.

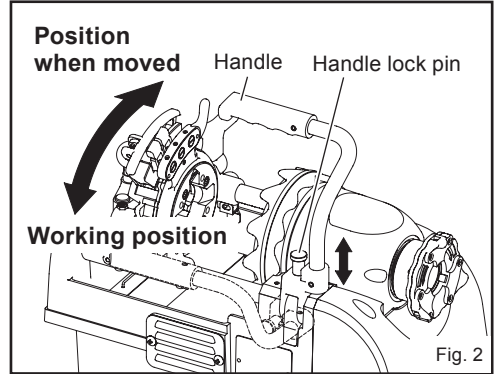

Fig. 2

2. Setting up (Fig. 3)

Place the machine on a flat surface. (Even when placed on a flat surface, the rear chuck of the machine is designed to be in a slightly raised position).

⚠ CAUTION

If the rear chuck is too low, oil will flow out of the pipe, making the floor dirty and wasting oil.

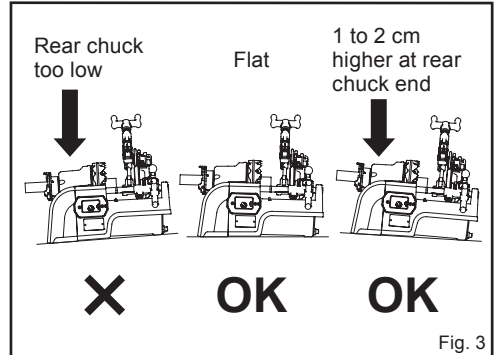

Fig. 3

3. Cutting oil (Fig. 4)

Fill the tank with the cutting oil that is supplied with the machine. Use only genuine WHEELER-REX cutting oil. (Fig. 4)

Using this oil for threading pipes made of other materials may result in irregular threads.

Genuine WHEELER-REX thread cutting oil



- For Steel pipe**
- 60603 2 Quart ThreadMaster Oil
 - 60601 1 Gallon ThreadMaster Oil
 - 60602 5 Gallon ThreadMaster Oil

- For Stainless Steel pipe**
- 60607 1 Gallon ThreadMaster Oil for SS
 - 60608 5 Gallon ThreadMaster Oil for SS

Fig. 4

4. Attaching and removing the die head (Fig. 5)

Removing the die head

- (1) Loosen the lock screw on the carriage.
- (2) Raise the die head slightly in the direction of arrow A and then pull it in the direction of arrow B. Raise the cutter if it gets in the way.

Attaching the Die head

- (1) Attach the die head that matches the size of pipe to be threaded. (Fig. 5)
- (2) Align the die head post with the carriage fitting hole, and push it until it contacts the carriage while moving the die head up and down a little.
- (3) Lower the die head and check it is positioned correctly.

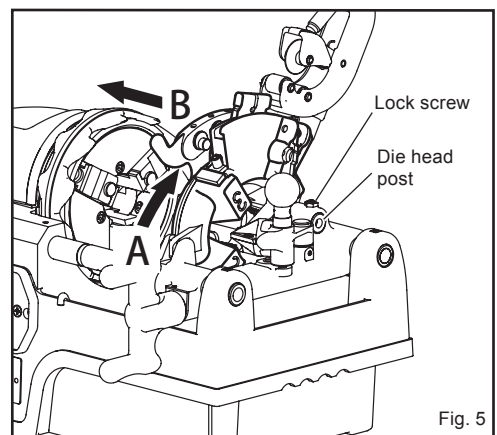

Fig. 5



GETTING READY / OPERATION GUIDE

5. Self-opening Die Head

Note
 15A: 1/2"
 20A: 3/4"
 25A: 1"

Main Parts

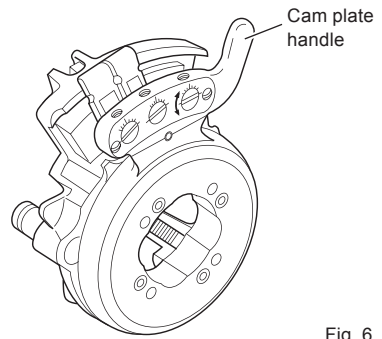
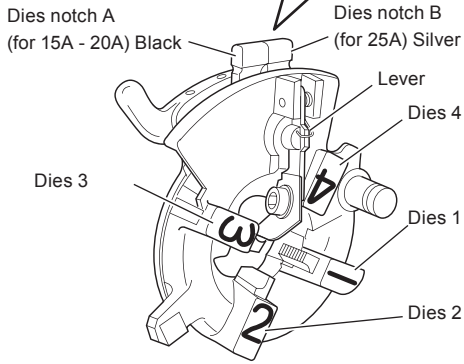
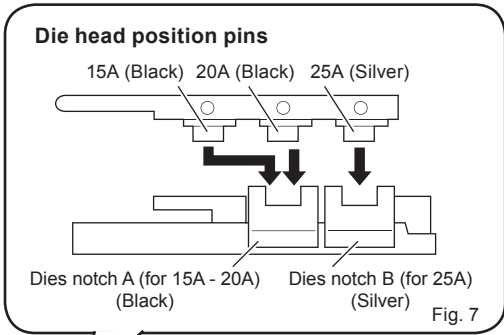

Fig. 6

How to adjust the thread cutting size

The standard die head is suitable for three pipe sizes: 15A, 20A, 25A. For 15A and 20A pipes, put dies notch A (black) on the respective die head over the eccentric position pin (black). For 25A, put dies notch B (silver) on the 25A die head over the eccentric position pin (silver). (You will need to change dies.)

Replacing the dies

Since 15A, 20A and 25A each have different thread pitches, the dies need to be changed accordingly. When replacing the dies, please follow the instructions below.

- (1) After opening the die head (i.e. with the open lever removed from the groove on the block and the dies in the open position) remove the size setting lever from the size setting pin.
- (2) Turn the cam plate handle in the direction of the arrow: dies No.3 and No.4 can then be removed.
- (3) Raise the die head and remove dies No.1 and No.2.

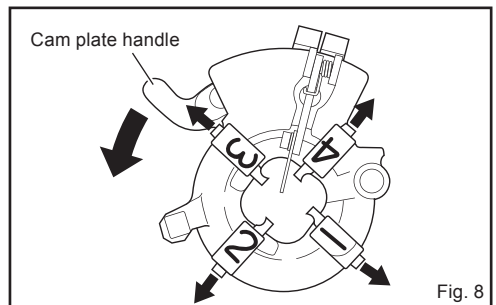

GETTING READY / OPERATION GUIDE

Attaching the Dies

- (1) Use the removal procedure in reverse to insert the dies in the die head.
- (2) Insert the dies in their corresponding die slot on the die head and push them in until they click into place.
- (3) Raise the die head and insert replacement dies No.1 and No.2 until the notch is engaged.
 - * Ensure that the number on the dies corresponds to the number on the die head; if dies are inserted incorrectly, cutting will be impaired.
- (4) Turn the guide set knob in the direction of arrow 2, as shown in Fig.9; the dies will move towards the centre of die head. If the dies do not slip into position smoothly, try to move them up and down a little, repeating this procedure as necessary.
 - * Dies are made as a matched set of four, so be sure to use them as such and replace them all at the same time. Do not attempt to replace just one or two dies in the set, as cutting will be adversely affected.

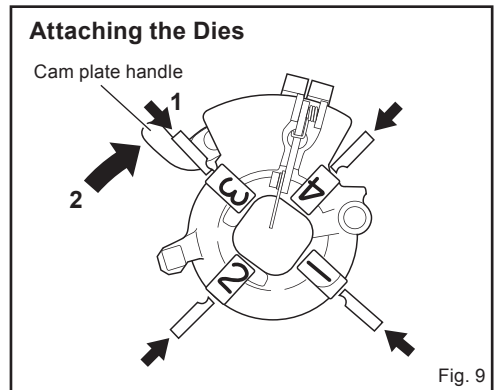

Adjusting the length of the thread

- (1) Press auto open lever A, put the dies in the open position, and loosen the socket head cap screw a little.
- (2) Adjust the auto open lever according to the length of the thread to be cut, i.e. towards the reamer for long threads and towards the cutter for short threads.
- (3) Tighten the socket head cap screw securely again.

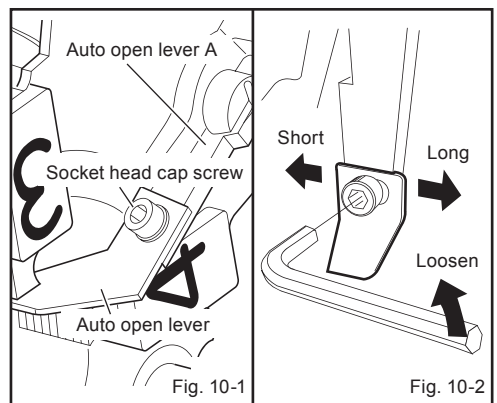

Microfine Adjustment of Thread Thickness

Microfine adjustment of thread thickness allows pipes to be cut exactly to your requirements.

- (1) Slightly loosen the lock bolt on the eccentric pin.
- (2) Simply turn the microfine adjustment knob to the left to decrease, and to the right to increase thread thickness.
- (3) The knob is locked by a locking bolt which should be loosened with the hexagonal key provided and the knob turned three settings to the right before adjustments are made.
 - * Size should always be checked with a thread gauge after adjustment.

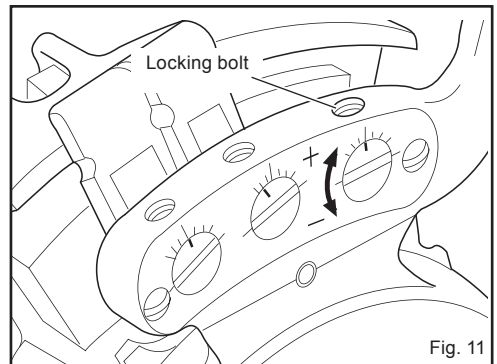

Adjustment of Thread Depth

If, even with full adjustment, thread size is not satisfactory, remove the retaining pin and reinsert the size adjustment plates. Hold in place with the retaining pin.

- (1) Raise the auto open lever (Fig.10-1), and, with the die head open, loosen the retaining pin with a flathead (minus) screwdriver.
- (2) Hold on to the size setting plate and remove the retaining pin.
- (3) Be careful not to let the notch pin and the spring come out of the size setting lever.
- * If the notch pin and spring in the size setting lever come out, place them back again in the hole in the opening block.
- (4) Select and insert the size adjustment plate as shown in Figs. 12-1 and 12-2.
- (5) Lock in position by pressing down on the notch pin and spring with the size setting lever.
- (6) Pass the axis of the notch through the rounding block and set the size setting lever, size adjustment plate.
- (7) Finally, tighten the retaining pin securely with a flathead (minus) screwdriver.

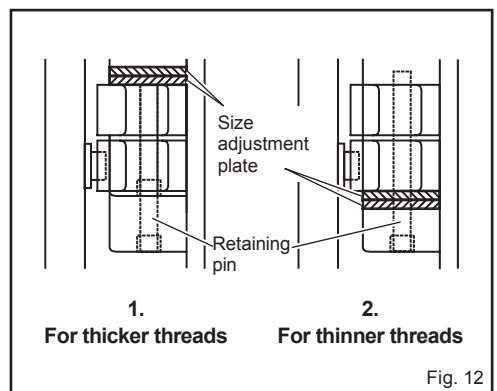

GETTING READY / OPERATION GUIDE

6. Manual-open die head (There is no need to remove the die head from the machine).

Removing the dies

- (1) Knock the eccentric handle to the right, loosen the lever nut and push the eccentric handle over to the far left. (Fig. 13) In this position, dies No. 3 and No. 4 can then be removed.
- (2) Raise the die head and you can remove dies No. 1 and No. 2.

Replacing the dies

- (1) Remove the die head.
- (2) Lower the die head and replace dies No.3 and No.4 in the same way. Insert each die until the notch is engaged. (Fig.14)
- (3) Raise the die head and insert replacement dies No.1 and No.2 until the notch is engaged.
 - * Ensure that the number on the dies corresponds to the number on the die head; if dies are inserted incorrectly, cutting will be impaired.
 - * Dies are made as a matched set of four, so be sure to use them as such and replace them all at the same time. Do not attempt to replace just one or two of the set as cutting will be adversely affected.
- (4) Pull the eccentric handle back in the opposite direction, left of the arrow. The dies will move towards the centre of die head.
 - * If the eccentric handle does not move into position properly, move the dies up and down a little while pushing and pulling the eccentric handle gently and try again.
- (5) Adjust according to your desired thread cutting size (see 'Threading').

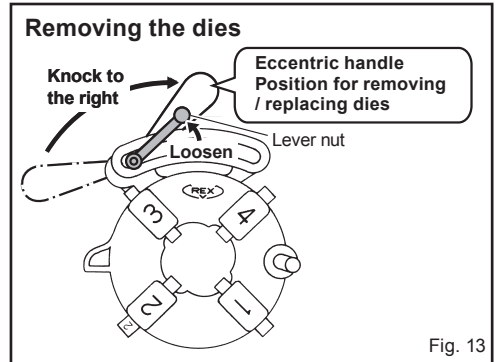

Fig. 13

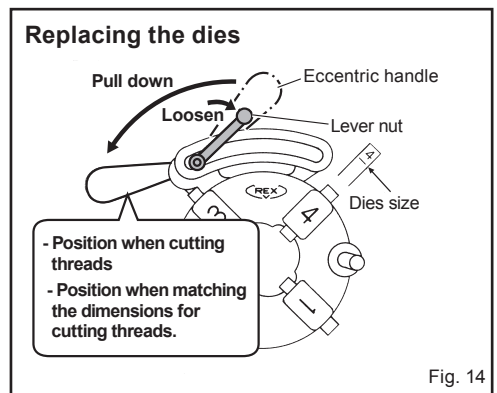

Fig. 14

Ensure the handle is lowered when the machine is in use. (Pg. 6, Fig. 2)

7. Setting up the pipe / Removing the pipe

⚠ WARNING

- Do not install or remove a pipe when the machine is still switched on, when operating the machine, or just after you switch it off. If you do, you may get entangled in moving parts, leading to accident or injury. Restart work after you make sure the machine has come to a complete standstill.
- When installing or removing the pipe, remove the plug from the power outlet or the machine could suddenly start up leading to injury or accident.

- (1) Open the hammer chuck and rear chuck wider than the size of the pipe to be threaded, inserting the pipe from the rear chuck side where possible. (Fig. 16) (Note: In the case of short pipes, insert from the chuck side).
- (2) Close the rear chuck and, holding the pipe in your right hand, close the hammer chuck with your left hand to place a grip lightly on the pipe and make sure the chuck jaw inserts engage the pipe properly. Pull the hand-wheel sharply towards you to lock.
- (3) A sharp jerk in the opposite direction will release the pipe once you have finished threading. Next, remove the pipe after releasing the rear chuck.

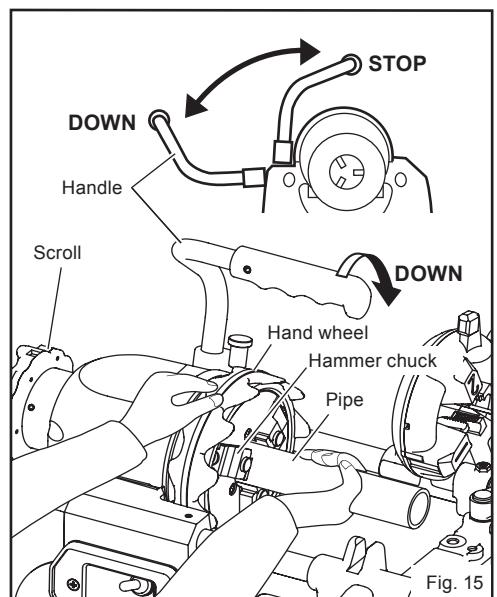

Fig. 15

GETTING READY / OPERATION GUIDE

Suggestions for short pipes

- Lightly grip the pipe with the chuck, gently engage the dies with the end of the pipe to be threaded, and then tighten the hammer chuck again. (Fig. 16)

Note: Chuck the pipe with the pipe protruding at least 60mm from the edge of the chuck jaw insert. (Fig. 16)

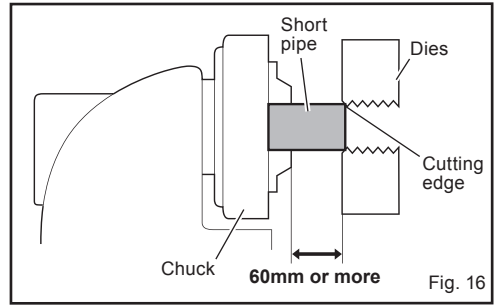

Suggestions for long pipes (Fig. 18)

- When threading long pipes, use a pipe support to avoid excessive vibration etc. while the pipe is rotating, and to prevent the machine from becoming unstable under the weight of the workpiece. (Fig. 18)

<p>Use WHEELER-REX pipe support Keeps long pipes stable</p>	 <p>Fig. 17</p>
--	--

⚠ WARNING

Not using a pipe support may result in irregular threads, damage to the machine and/or accident or injury.

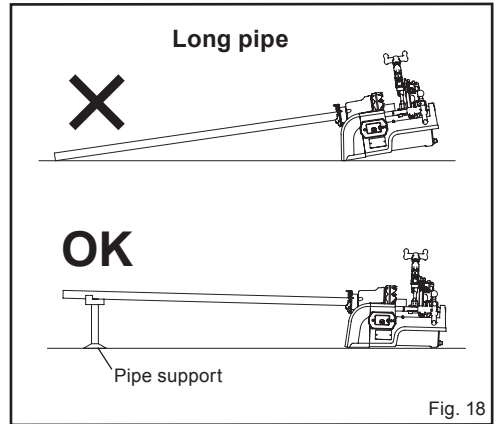

8. Power supply (Fig. 19)

Before using the unit, check the voltage on the nameplate. Use only an AC power supply. If an extension cord is used, it must be as short as possible and of sufficient capacity for the power supplied (use at least a 2 mm² flexible cable, 20A for 110-120 V. (Fig. 19)

⚠ WARNING

- Before connecting the plug to the socket, check that the switch is turned OFF to prevent abrupt movements that could lead to accident or injury.
- When you use a 110 – 120 V power supply, ensure it is earthed or you may get an electric shock. If the power socket is already earthed, first remove the adapter provided with the earth.

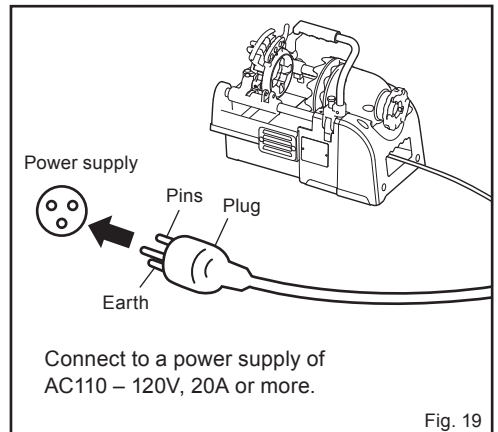

GETTING READY / OPERATION GUIDE

⚠ WARNING

Carry out the following checks before starting to cut or thread pipes.
Should any problems arise, refer to "Troubleshooting" at the end of this manual and follow the appropriate instructions.
Continuing to use the machine when a problem has arisen can lead to accident or injury.

9. Checks before starting

- (1) Turn on the machine to set the main shaft in motion. (Fig. 20)
 - Check there are no abnormal sounds or odours coming from the motor.
 - Check the pipe you installed does not vibrate abnormally. If it does, install it again.
- (2) Check that cutting oil flows as it should from the die head. (Fig. 21-1)
Confirm that there is at least 1 liter of cutting oil in the tank. (tank capacity:1.5 L)
When the volume of oil emitted from the die head is reduced, check that the amount of cutting oil in the tank is at least sufficient to cover and hide the strainer. (Fig. 21-2) Replenish the oil as required.
 - * If the volume of oil flowing from the die head remains low even after the oil has been added, please contact your distributor or WHEELER-REX.
- (3) Allow the machine to rotate without any load for several minutes.
 - Check the motor does not become abnormally hot, etc.
- (4) Turn the machine off and allow it to stop rotating.
 - Check there are no abnormal sounds or odours coming from the motor. The unit uses a motor equipped with a built-in braking system for improved safety. Make sure you read and understand the points below relating to the use and performance of the system.

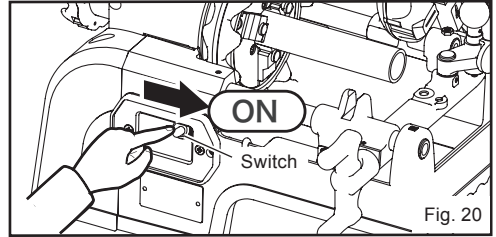

Fig. 20

Confirming the amount of thread cutting oil / Die head

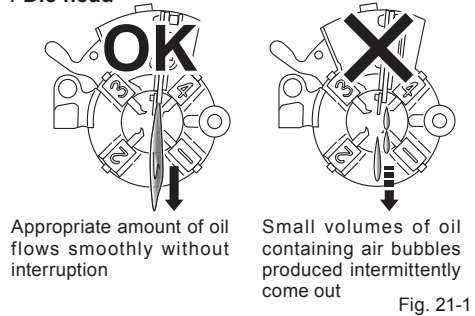

Fig. 21-1

10. Motor with braking system (Fig. 22)

The braking system in the motor is designed to minimise idling after turning the machine off, and to prevent unexpected accidents and injuries. The motor can stop within fewer rotations than conventional ones. However, under certain conditions the braking system may not engage correctly or it may become ineffective. Read the following cautions carefully to ensure correct use.

Checking the amount of thread cutting oil /Oil tank

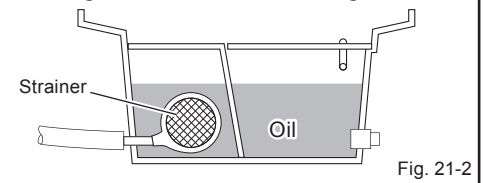

Fig. 21-2

Please note that the effectiveness of the brake will be diminished in the following cases.

Problem	Remedy
The carbon brushes are worn out.	Replace with new ones according to the procedures on Pg. 17, Fig. 40.
When the motor becomes overheated from continuous use	Wait for the motor to cool down and start again.
When an oxide film is generated in the motor	Allow the motor to rotate for about 10 minutes with no load.

If the brake does not work even under such circumstances, contact your distributor or WHEELER-REX.

Table 3

⚠ WARNING

1. Make sure the braking system is working before using the machine.
 - Although this machine is equipped with both a braking system and a safety switch, the brake may not work or it may become ineffective depending on conditions. Check the effectiveness of the brake before use, and wait till the motor comes to a complete stop before moving on to the next operation.
2. Be sure to use REX carbon brushes.
 - Using other brushes may damage the motor or the machine itself, or the brake may not be applied.
3. Do not use the machine in rain, humid or damp places, or places where moisture can easily get into the machine.
 - If stored for long periods in a humid place, an oxide film may form on the motor, and the brake may not be engaged. Store in a place with low humidity.

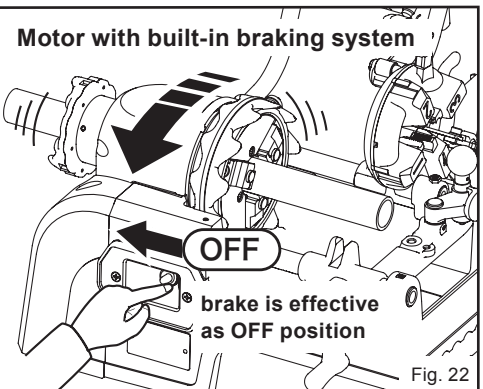

Fig. 22

GETTING READY / OPERATION GUIDE

11. Cutting pipes

- (1) Raise the die head and reamer.
- (2) Position the pipe so that it is ready for cutting, and fasten the pipe securely with the hammer chuck.
- (3) Open the pipe cutter wider than the diameter of the pipe, lower it into position and turn the cutter handle, bringing the cutter close to the position where the blade and roller lightly press against the pipe.
- (4) Switch the machine on and turn the cutter handle up to ½ a turn for each rotation of the pipe. (Fig. 23)

* Note: When starting to cut a pipe, apply gradual pressure while tightening the wheel lightly against the pipe. If too much force is applied, the shape of the pipe may easily be distorted, resulting in imperfect threads.

* Note: If the cutter handle is turned too quickly, it will affect the shape and finish of the thread.

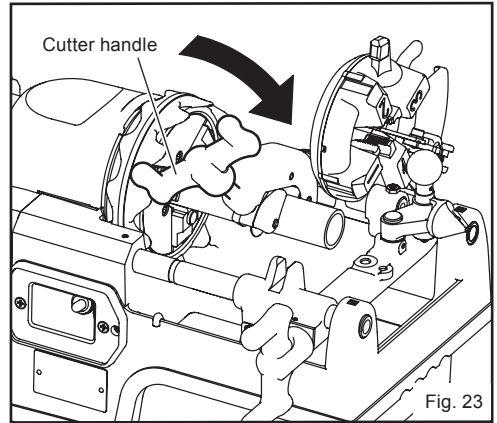

When cutting a stainless steel pipe, use a **stainless steel pipe cutter wheel (product code: 135071)**.

⚠ CAUTION

Be sure to position the cutter correctly before the pipe starts rotating. If it is not in the correct position it could damage the pipe or the machine.

⚠ WARNING

1. Use a pipe support when threading long pipes.
 - If the pipe to be cut is very long, ensure you create a stable situation before starting. Use a proper pipe support so that the cutter will not be overloaded by the heavy weight of the long pipe just before or during the cutting process while the pipe is rotating. This will prevent the machine from becoming unstable under the weight of the workpiece. If a pipe support is not used, threading cannot be performed correctly, causing problems with the machine, and may even result in accident or injury.
2. Pipe cutter may break.
 - Be sure to wear safety glasses, and keep your hands and face away from the pipe cutter. Fragments may scatter, causing accidents and injuries.
3. Always use genuine REX parts for the cutter.
 - If you use anything other than genuine parts, the machine will malfunction, resulting in accident or injury etc.

Special precautions when you cut a pipe using another pipe cutter (Fig. 24)

We strongly recommend that only the pipe cutter attached to the machine be used to cut pipes. If another cutter is used, ensure that the pipe end is at right angles to the axis of the pipe. (Fig. 24-A) If the pipe is not square on, as in Fig. 24-B and C, threads may be defective. Illustrations B and C may be the result of the following:

Fig. 24-B

- The bearing or chucking of the cutter is unstable.
- When a grinder is used with excessive force (especially in the case of large diameter pipes.)
- When the pipe is engaged at an angle when cutting.

Fig. 24-C

- When you have cut a large diameter pipe 2 or 3 times with a small grinder.

⚠ CAUTION

If the end of the pipe is slanted (Fig. 24-B) or has steps in it (Fig. 24-C), it is not only impossible to make a perfect thread, but may even result in damage to the machine, accident or injury, etc..

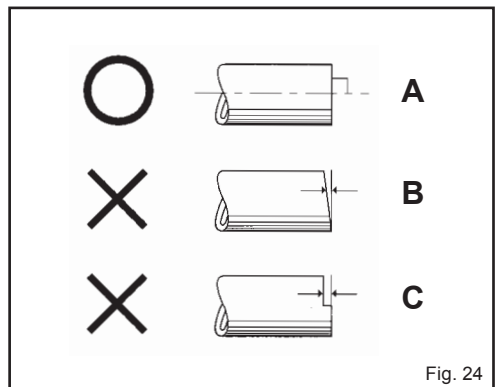

GETTING READY / OPERATION GUIDE

12. Reaming

After cutting the pipe with the pipe cutter, be sure to use the reamer to chamfer the inside of the pipe before making a thread.

- (1) Lift the die head and pipe cutter out of the way.
- (2) Lift up the set knob on the reamer and put the reamer in the chamfering position. (Fig. 25)
- (3) Turn the machine on to start the pipe rotating. Then turn the carriage handle to the right to move the reamer forward to engage the pipe. Allow the pipe to rotate at least ½ a turn, and then remove the reamer from the pipe. That completes the reaming process. (Fig. 26)

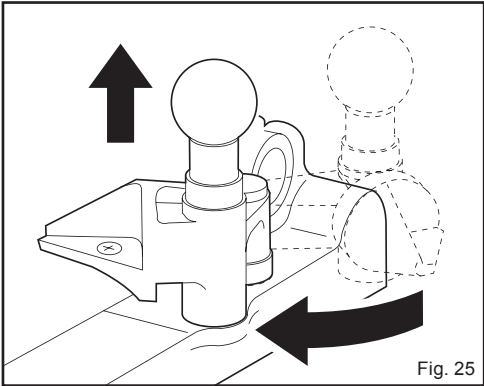

Fig. 25

⚠ CAUTION

- Do not use excessive force when pressing the reamer against the pipe as this may scratch the pipe or even damage the machine.
- The reamer blades are extremely sharp. NEVER touch them with your bare hands, as you could be seriously injured.

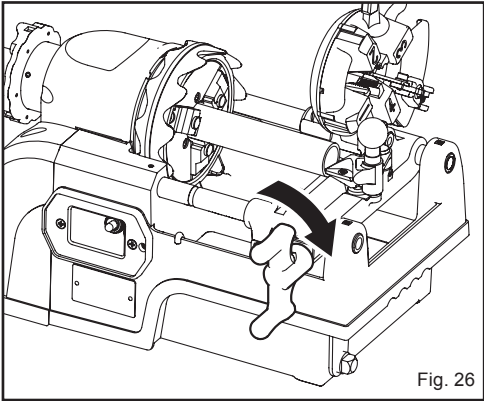

Fig. 26

Before threading a pipe

13. Carriage collision prevention mechanism (Fig. 27)

When threading a very short pipe, the carriage may hit the chuck and cause serious deformation or damage to the machine. The "collision prevention mechanism" is designed to stop the motor automatically when it is on the verge of colliding and prevent damage to the machine.

- (1) When the carriage approaches the chuck, the rod also approaches the switch and is pushed forward.
- (2) As the carriage moves forwards, the rod pushes onto the main switch just before a collision occurs and the machine stops.
- (3) Since the pipe is far too short, make sure you extend its length in order for the process to be carried out properly. (Refer to Pg. 10 "Suggestions for short pipes".)

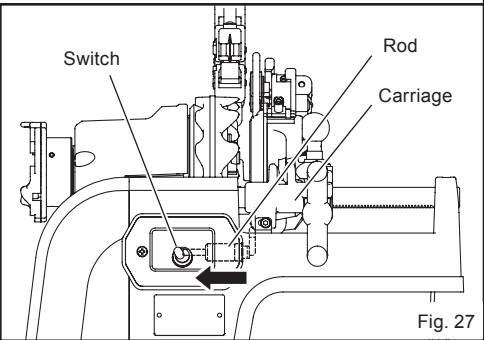

Fig. 27

⚠ CAUTION

Start the thread cutting process with the carriage to the right of the red line on the front support bar. (Fig. 28)

14. Improper use of a pipe wrench (Fig. 28)

As shown in Fig. 28, a pipe is positioned in the machine and a wrench is being used to tighten the fitting: never do this as there is high risk of damaging the machine.

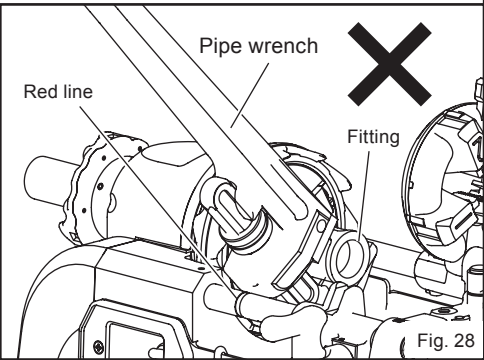

Fig. 28

GETTING READY / OPERATION GUIDE

15. Cutting threads (Self-opening Die Head)

Raise the cutter and reamer, and align the die head with the proper position. Look around the work site to make sure it is safe to begin operating the machine.

* Make sure the handle is in the lowered position (as shown on Pg. 6, Fig. 2) before you start cutting threads.

Match the correct die head and dies to the diameter of the pipe. Similarly, make sure you use the right dies and oil for stainless steel pipe.

(1) Push the guide set knob forward and align the die head with its proper position. Check to make sure that the unit is set to the desired size (Fig. 29).

To change size: (Fig.30)

1. Push the positioning notch in the direction of arrow 1 in Fig. 30.
2. Align the positioning notch with the desired pipe size as displayed on the size indicator plate. (arrow 2)
3. Finally, push the positioning notch in the direction of arrow 3 and, at the same time, insert the positioning pin in the notch groove.
- (2) Push the guide set knob in the direction of arrow 4 until it stops. The die head is now set in position. Switch on the machine and the thread cutting oil will automatically flow out of the die head.
- (3) Turn the carriage handle to the right to advance the die head against the pipe and allow the dies to begin cutting (Fig. 31)
- (4) Once three or four threads have been cut, the remainder will be cut automatically. When the prescribed thread length is reached, the dies will be released by the auto-open lever.
- (5) Turn the carriage handle to the left to release the die head from the pipe.

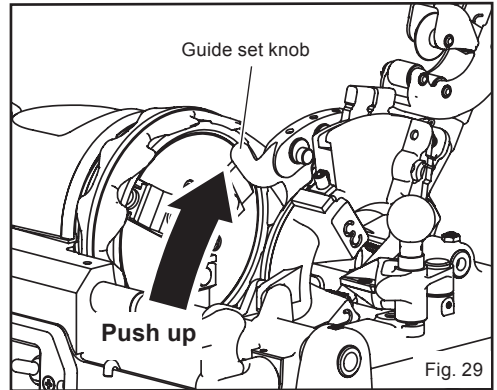

Fig. 29

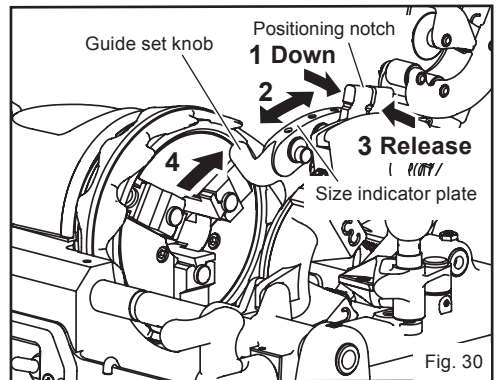

Fig. 30

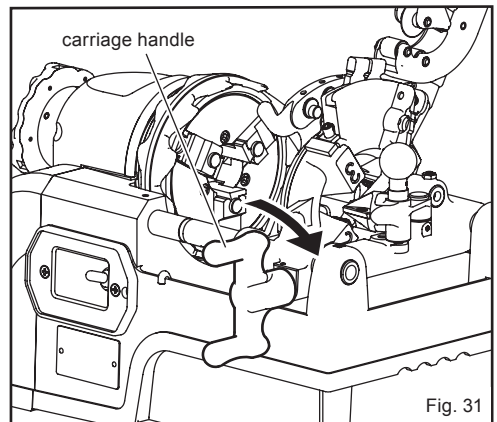

Fig. 31

⚠ WARNING

When threading is completed, the self-opening die heads suddenly open. There is a possibility of oil splashing out or metal flakes flying out, which might result in accident or injury. Avoid placing your hands or face too close to the machine.

Precautions when threading

- Care when the dies come into contact with the pipe (Fig. 32)

Engage the cutting edge of the dies very lightly with the end of the pipe. Bringing the dies too forcefully into contact with the pipe will result in damage to the dies and shorten their working life. Once the dies come into contact with the pipe, initially apply light pressure to the carriage handle in a clockwise direction and then gradually increase the amount of force to cut firmly. As the dies cut into the pipe, it is no longer necessary to apply pressure to the carriage handle as the carriage will move on its own.

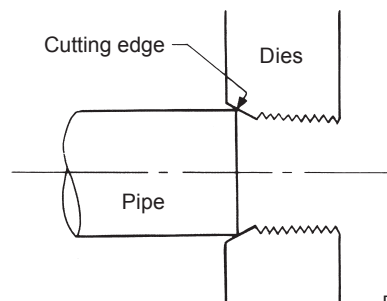

Fig. 32

GETTING READY / OPERATION GUIDE

16. Cutting threads (Manual-open Die Head)

- (1) To match the size of the thread, align the scale on the eccentric link with the thread size on the size scale of the die head, and then tighten and fix the lever nut in position (Fig. 33).
- (2) Turn the machine on and oil will automatically flow from the die head.
- (3) Turn the carriage handle to the right to engage the pipe with the dies. Cut 3 or 4 threads and threading will then be performed automatically. (Fig.34)
- (4) When the thread has been cut to the prescribed dimensions, slowly raise the eccentric handle in the direction of the arrow and release the dies to complete the threading process. (Note: If you release the dies too abruptly, it may result in an imperfect finish such as a step-edged thread). (Fig. 35)
- (5) Finally, complete the process by releasing the die head from the pipe by turning the carriage handle to the left. If you place the die head in the raised position, the flow of oil will stop. (Fig. 35)

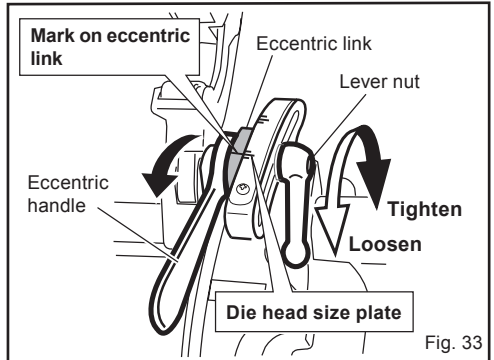

Fig. 33

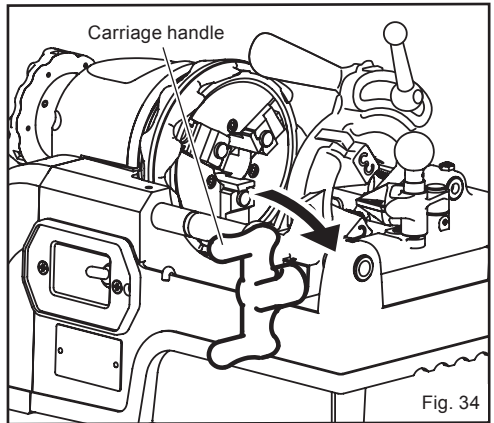

Fig. 34

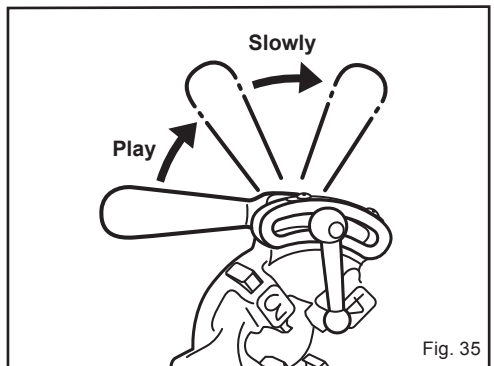

Fig. 35

Points to watch when threading

- (1) Before adjusting the size of the thread to be cut, bring the eccentric handle towards you, until it is in the position indicated. (Fig. 36-1)
- (2) Lightly tighten the lever nut securely by hand. No hammering is required etc.
- (3) Thread size can be simply adjusted with the lever nut. Move it towards you to increase, and away from you to decrease the thread size. (Fig. 36-2)

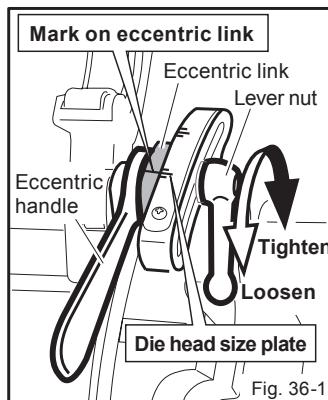

Fig. 36-1

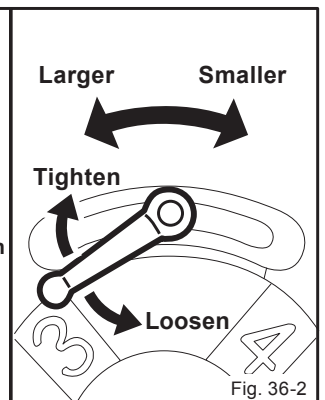

Fig. 36-2

GETTING READY / OPERATION GUIDE

17. Measuring threads with a gauge

Unacceptable threads (Fig. 37)

When connecting the male thread on a cut pipe to the female thread in the joint, various factors that could lead to leakage should be considered. The following examples may be due to the male thread on the pipe end.

(1) Irregular shaped threads (Fig. 37 - 1)

How to distinguish irregular shaped threads

- (A) Visually inspect the thread after wiping off any oil or dirt with a rag; look for any wave-like formation.
- (B) Gently check the surface of the thread with your fingers, feeling for any irregularity.
- (C) Check if bits of scrap have been produced when cutting.

(2) Check if the diameter of the thread is too small or too large (Fig. 37 - 2)

Check with a thread gauge.

(3) Distorted threads (in the case of manual die heads) (Fig. 37 - 3)

When cutting threads that are wider than the width of the dies, you can gradually open up the eccentric handle; but then if you leave the eccentric handle in the same position and cut a thread longer than the width of the dies, the taper will remain the same width as the die and the rest of the thread will be straight.

(4) Threads are too small (Fig. 37 - 4)

(5) The thread is chipped (Fig. 37 - 5)

(6) Thread with uneven thickness (Fig. 37 - 6)

* Choose an appropriate method for checking the threads on joints and other connections, such as using sealants, washing the joint, checking the torque etc.

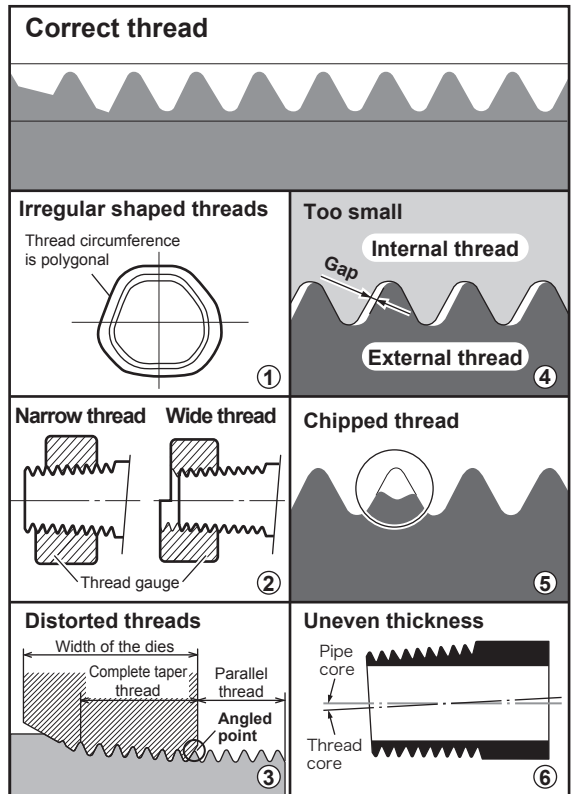

Fig. 37

⚠ CAUTION

Threads may be affected by the sharpness of the dies, cutting oil etc., so be sure to use a thread gauge (Fig. 38) to check the thread.

* This is especially important after you have changed the die set

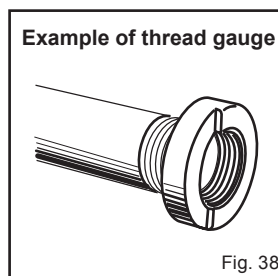

Fig. 38

DAILY INSPECTION, MAINTENANCE

⚠ WARNING

- Before inspecting or performing maintenance on the unit, always set the switch to the OFF position and remove the plug from the power outlet. If the unit is left plugged in, it may begin operating unexpectedly, resulting in injury.
- If you discover any problems during inspection or maintenance, check the symptoms in "Troubleshooting" and take the appropriate action as noted in the table. Continued use of the unit without correcting the problem may result in overheating, smoke or fire and lead to accident or injury.

1. Oiling the pipe cutter (Fig. 39)

Before you operate the machine, be sure to maintain adequate lubrication by applying spindle oil or machine oil to the thread on the cutter handle, roller shafts and blades once a day.

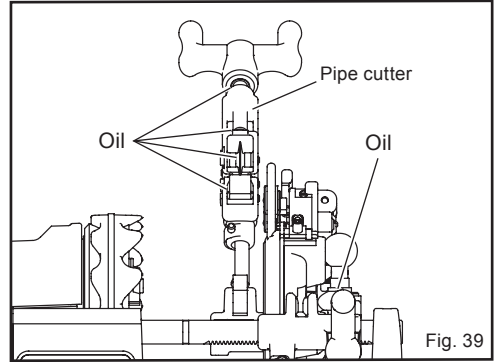

2. Replacing the carbon brushes (Fig. 40)

- To protect the motor, the unit is equipped with two auto-stop carbon brushes. When these brushes get too worn, the motor will not operate even when the unit is turned on.
- Be sure to use REX original carbon brushes. Using other brushes may damage the motor.

⚠ CAUTION

- Always replace both carbon brushes as a set.
- Be sure to use REX original carbon brushes.
- Using other types of carbon brushes may damage the motor or the machine, or cause accidents.
- When replacing the carbon brushes, always make sure the unit is stable. Trying to replace the brushes with the unit tilted is extremely dangerous, as the unit may fall over.

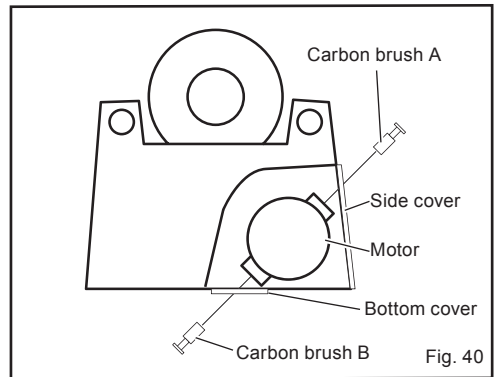

Replacing the carbon brushes

Replacing carbon brush A (Fig. 41)

- Remove the side cover from the side of the unit and, using a flathead screwdriver, remove the carbon brush cap attached to the motor inside. Then replace the carbon brush.

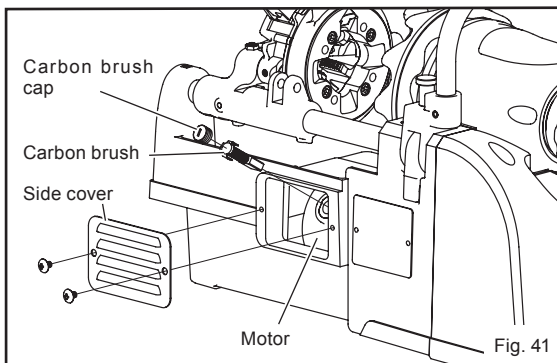

Replacing carbon brush B (Fig. 42)

- Remove the bottom cover and, using a flathead (minus) screwdriver, remove the carbon brush cap attached to the motor. Then replace the carbon brush.

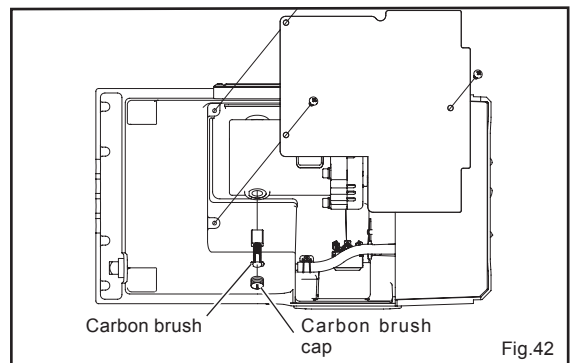

DAILY INSPECTION, MAINTENANCE

3. Cleaning the oil tank (Fig. 43)

Fine chips of scrap accumulate in the tank, be sure to clean it at least once a month. (Fig. 43) This will improve the flow of cutting oil and prolong the life of the pump.

- * There should be 1.5 liters of cutting oil in the tank.
- * Use only genuine REX thread cutting oil (P6, Fig.4).

Cleaning the machine

- (1) Move the carriage to the left.
- (2) Hold the tank upper cover (L), and pull it up to remove it.
 - First loosen the wing bolt, and while holding onto the wire, lift up and remove the scrap tray.
- (3) Remove the tank upper cover (S), and wipe off any chips adhering to the tank upper covers (L) (S).
- (4) Loosen the drain plug with a wrench and drain off the cutting oil from the tank.
 - Remove the strainer by using a Phillips screwdriver to loosen the round head screw that fastens the oil tube to the strainer.
- (5) Replace and tighten the drain plug once all the scrap in the tank has been removed. Put the strainer back before filling the tank with new cutting oil.

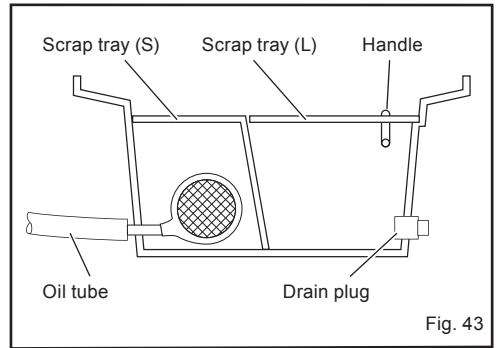

Fig. 43

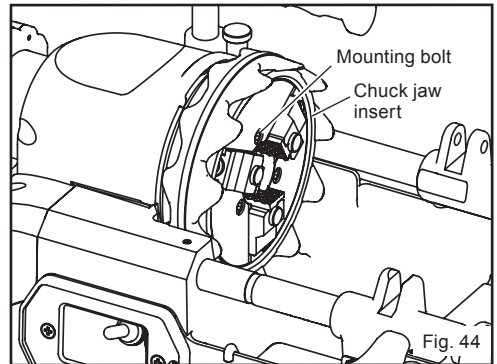

Fig. 44

⚠ CAUTION

To avoid injury, do not touch the reamer blade directly with your hands while removing the tank upper cover and cleaning the tank.

4. Chuck configuration and Care (Fig. 44-45)

Clean any clogging deposited on the chuck inserts with a wire brush etc. Always keep the inserts clean. When the chuck jaw inserts need replacing, contact your distributor or WHEELER-REX. When replacing the chuck and the chuck jaw inserts, be sure to replace them with an 7991 model RT type chuck, and NS type for chuck jaw inserts.

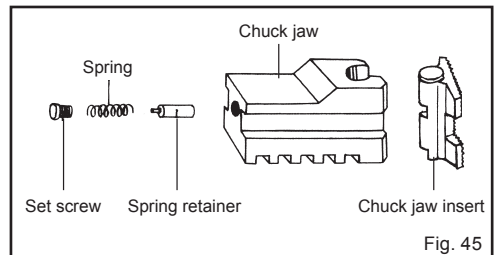

Fig. 45

5. Wiring diagram (Fig. 46)

AC 110

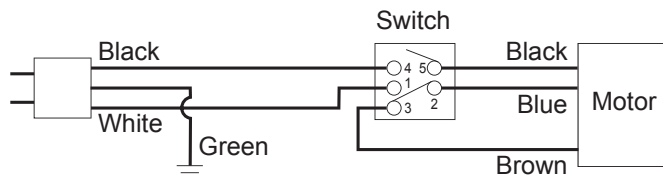

Fig. 46

REQUESTING REPAIRS

This machine is produced with great precision. Should it not operate normally, never attempt to repair it yourself. Always ask your distributor or WHEELER-REX for repairs.

Please contact us if you need any parts or have any questions about REX products.

Availability of maintenance parts

Maintenance parts for this product shall be available for a period of 7 years after manufacture of the product has stopped.
Electric parts, however, shall be maintained for 5 years.



SERVICING AND REPAIRS

If you find any abnormality with the product, please check the following and contact the distributor from whom you bought the machine, or WHEELER-REX.

⚠ CAUTION

If any problems occur that are not dealt with below, do not attempt an overhaul or repair by yourself, but ask your distributor or WHEELER-REX to service the machine.

If repairs are attempted by anyone without the proper knowledge and skills, optimum performance will be impaired and accidents and injuries may occur.

Cause of and measures to take when problems occur (TROUBLESHOOTING)

Problem		Cause	Remedy
Machine does not operate properly when turned on.	The motor is not running.	The plug is disconnected.	Insert the plug into the power socket.
		The carbon brushes are worn.	Replace with new ones according to the procedures on Pg. 17.
		Voltage is low.	Check the voltage. (Pg. 10)
		The motor is burned out.	Repairs are needed.
	The switch is damaged.		
	The motor is running.	The gear is broken.	
Rotation of the main shaft is defective.		Voltage is too low.	Check the voltage. (Pg. 10)
		The motor is burned out.	Repairs are needed.
Even if the switch is turned off, the machine does not stop smoothly (braking system is ineffective)		The carbon brushes are worn.	Replace with new ones according to the procedures on Pg. 17.
		Lead wire is disconnected.	Wire as per wiring diagram on Pg. 18.
		Other causes	See "Motor with braking system" on Pg. 11.
No oil flow.		Amount of oil is too low.	Replenish the oil.
		Scrap clogging the flow.	Remove scrap in the oil tank.
		The die head is not fitted correctly.	Fit the die head in the correct position.
Oil flows out of the back of the pipe.		Rear chuck is set too low.	Raise the rear chuck.
Difficulty in attaching the die head.		Scrap is in the way.	Remove scrap attached to the die head post and hole.
		Die head is obstructed by cut-off pipe etc. on top of the tank cover.	Remove the obstruction.
Moving parts do not move smoothly.		Moving parts blocked by scrap.	Remove scrap.
Moving parts do not move smoothly.		The dies are worn.	Replace with new ones.
		The dies are chipped.	
		The dies are not inserted in the correct position.	Match the dies to the number on the die head.
Threading cannot be performed correctly.	Too Large/Small	The die head is not adjusted correctly.	Adjust the die head according to the procedures on Pgs. 13 - 17.
	Too Long/Short		
		The dies are worn.	Replace with new ones.
		The dies are chipped.	
		Thread cutting oil has deteriorated.	Replace with new oil.
Stops while cutting a thread		The dies are not inserted in the correct position.	Match the dies to the number on the die head.
		The carriage collision prevention mechanism is working.	Refer to the procedure of P10 to lengthen the pipe workpiece from the chuck.
		Voltage is too low.	Check the voltage. (Pg. 10)

Table 4



WHEELER-REX

REX International U.S.A., Inc.

P.O.Box 688, 3744 Jefferson Road, Ashtabula, OH44005

Ph:440 - 998 - 2788 · Fax.: 440 - 992 - 2925

Toll Free: 1 - 800 - 321 - 7950

Website: www.wheelerrex.com

Manufacturer:

REX

REX INDUSTRIES CO., LTD.

8V370-WH2
8991
1809D0100