

50/60Hz



PIPE THREADING MACHINE

8090

OPERATION MANUAL

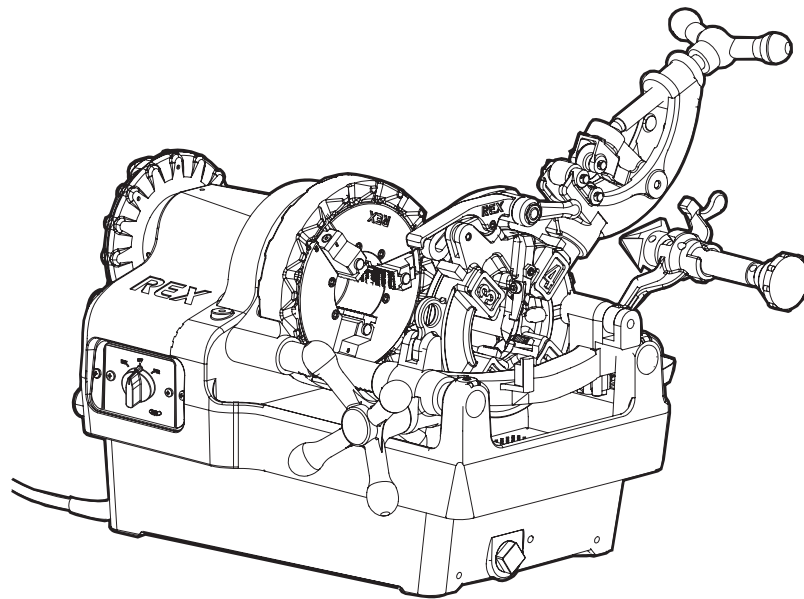

| | |
|---|---|
|  | Be sure to read this Operation Manual before using the machine. |
|---|---|

| | | |
|--|--|--|
| - Note - | | |
| - Be sure to hand this operation manual to the user. | | |
| - To ensure safe and efficient use, read the manual thoroughly before using the machine. | | |
| - Be sure to keep the manual where the operator can refer to it whenever necessary. | | |

| | | |
|-------------------|------|-------|
| Date of purchase: | Year | Month |
| Distributor: | | |

Thank you for purchasing a WHEELER REX pipe threading machine.

Precision-engineered for cutting, reaming, threading and, with our optional Portable Groovers, grooving steel and stainless steel (option) pipes, our product will give you years of reliable service if you simply follow the instructions in this manual carefully.

Before using the machine, therefore, make sure you read the manual from start to finish, paying particular attention to the Safety Considerations on pages 1 & 2 and Precautions on pages 3 & 4. To avoid accident and injury, never use the machine for any purposes other than those described in this manual.

Should you need further advice, contact your distributor or WHEELER REX.

CONTENTS

| | |
|---|----|
| Safety Considerations | 1 |
| Precautions | 3 |
| Main Parts, Specifications, Standard Accessories, Usage..... | 5 |
| Getting Ready | |
| 1. Transportation | 6 |
| 2. Machine set up | 6 |
| 3. Thread cutting oil | 6 |
| 4. Attaching the die head | 6 |
| 5. Operating the die Head | 7 |
| 6. Setting up the pipe/Removing the pipe | 8 |
| 7. Power supply | 8 |
| 8. Check before starting | 9 |
| 9. Cutting pipe | 9 |
| 10. Reaming/Points to watch when threading | 10 |
| Operation Guide | |
| 11. Making threads (Optional Manual-open Die Head)..... | 11 |
| 12. Adjusting the oil flow | 11 |
| 13. Making threads (NV-auto Die Head) | 12 |
| 14. Measuring threads with a gauge/Precautions when threading | 13 |
| Optional Accessories | 14 |
| Maintenance and Care | |
| 1. Grease, Oil | 15 |
| 2. Replacing the carbon brushes | 15 |
| 3. Cleaning the oil tank | 16 |
| 4. Replacing/Installing the chuck jaw set | 16 |
| 5. Wiring diagram | 16 |
| Service and Repairs | 16 |
| Troubleshooting | 17 |

Definitions of **⚠ WARNING** and **⚠ CAUTION**

In this operation manual, warnings are divided into **⚠ WARNING** and **⚠ CAUTION**.

⚠ WARNING : indicates actions which could possibly result in death or severe injury to the user if the machine is used incorrectly.

⚠ CAUTION : indicates actions which could possibly result in injury to the user, or physical damage, if the machine is used incorrectly.

Even items described as **⚠ CAUTION** could have serious results under certain conditions.

Be sure to observe these warnings carefully as they greatly affect safety.

- If this operation manual is lost or damaged, promptly order a replacement from your distributor or our sales department.
 - Parts and specifications are subject to change without prior notice, due to improvements in quality, performance or safety standards. In such cases, the contents, photographs, illustrations, etc. in this manual may be different to the product you have purchased.
-

⚠ WARNING

1. Ensure you use the correct voltage.

- Be sure to use the voltage indicated on the name plate of the main unit or in the operation manual. If the voltage is different from the voltage indicated, overheating, smoke or fire may occur.

2. Check the switch is OFF before inserting the plug into the power supply socket.

- If the plug is inserted into the power supply when the switch is ON, the machine may start operating abruptly and is liable to cause accidents. Be sure to check the switch is OFF.

3. Be sure to avoid electric shock.

- Do not touch the plug with wet hands.
- Do not use the machine in rain or in places where moisture can easily get into the machine.
- Be sure to ground the machine to avoid electric shock.

4. Take notice of conditions at the work site.

- Do not use the machine in rain, humid or damp places, or places where moisture can easily get into the machine. Humidity will lower insulation of the motor and cause electric shock.
- Do not use close to flammable fluids or gases, such as gasoline and thinner. Fire or explosion might occur.

5. Use designated accessories and attachments.

- Do not use accessories and attachments other than those designated in the operation manual or our catalogues. Accidents or injuries might result.

6. In the following cases, turn the main unit OFF and pull the plug out of the power supply socket.

- When the machine is not in use or parts are changed, repaired, cleaned or inspected.
 - When accessories are changed.
 - When hazards are expected (including electric power failure).
- If the machine is plugged in, it may start operation unexpectedly, causing accidents.

7. If any abnormality is noticed, stop operation immediately.

- If the machine does not operate smoothly, or abnormalities such as unusual odours, vibration or noise are detected, stop operating the machine immediately.
- Check symptoms against the items in the section entitled, "Troubleshooting" at the end of this manual and observe the corresponding instructions. If the machine is used continuously, overheating, smoke or fire might occur, because of accident or injury.
- If overheating or smoke from the unit occurs, do not attempt an overhaul yourself but ask for an inspection and repair.

8. Keep the work site clean.

- Ensure you keep the work table and the work site in good order and well lit.
- A cluttered site and work table are liable to cause accidents.

9. Do not let unauthorised personnel near the machine.

- Do not let anyone other than authorised personnel touch the main unit or the power cord, or operate the machine.
- Do not let anyone other than authorised personnel enter the work site, especially children. Injuries might occur.

10. Do not use the machine with excessive force.

- To ensure safe and efficient operation, use within the capacity of the main unit. Applying force may not only cause damage to the product but could also result in accident or injury.
- Do not use the machine in any way that could cause the motor to lock, or cause smoke or fire.

11. Use the machine only for its designated purpose.

- Do not use the machine on pipe not specified in this manual. Using the machine for any purpose other than threading pipes, such as fastening the pipe to a joint etc. will not only damage the machine and/or motor but could also lead to accident or injury.

Safety Considerations

▲ WARNING

12. No loose clothing.

- Do not wear neckties, clothes with unbuttoned sleeves, loose clothing, accessories such as necklaces, etc.
- When working outdoors, it is recommended that you wear rubber gloves and non-slip shoes. Slippery gloves and shoes are liable to cause injuries.
- Wear safety caps, safety shoes, etc. according to the working environment.

13. Keep a firm footing and balance to avoid falling over and injuring yourself.

14. Remove tools such as wrenches.

- Before turning the switch ON, check that tools used for inspection and adjustment have been removed. If you use the machine when tools are left inside it, accidents and injuries may occur.

15. Operate the unit with great care.

- Always work with great attention to how you handle and operate the machine and to the surrounding conditions. Carelessness may result in accident or injury.

16. Do not handle the power cord carelessly.

- Do not carry the product by the cord, or pull the plug out of the socket with the cord.
- Do not place the cord near heated objects, fats & oils, cutters and objects with sharp edges.
- Take care not to tread on the cord, pull the cord or apply unnecessary force resulting in damage to the cord.

17. Perform careful maintenance daily.

- When changing accessories and parts, follow the instruction manual. Periodically inspect the power supply cord and plug. If damaged, ask your distributor or our sales department for repairs.
- If an extension cord is used, inspect the cord periodically and, if damaged, replace it.
- If extension cords are used outdoors, use extension cords designed for outdoor use to prevent electric shock, short-circuit or fire.
- Keep parts used for gripping dry and clean, and free of oil and grease. If your hands slip, you may be injured.

18. Check for damaged parts.

- Before using the machine, carefully check for damage to the protective cover and other parts, and check both normal operation and specified functions.
- Check for any abnormalities such as in adjustment of movable parts, tightening, damage to and installation of parts and all parts affecting operation.
- Do not use machines with a damaged power cord or plug. Doing so may cause electric shock or a short, circuit leading to fire.
- Do not use machines if the stop and start switches do not work properly. In replacing or repairing a broken protective cover and other parts, follow the operation manual. If no instructions are specified in the operation manual, ask your distributor or our sales department for repairs.

19. Store carefully when the machine is not in use.

- Store in a dry place away from children and locked with a key.

20. For overhaul and repair of the machine, ask an appointed REX agent.

- Our products comply with corresponding safety standards. Do not remodel.
- Be sure to ask your distributor or our sales department for any repairs. If repairs are carried out by non authorized repair center, the performance of the unit may be adversely affected and void warranty.

▲ WARNING - Proposition 65 -

This product can expose you to chemicals lead and lead compounds, which are known to the State of California to cause cancer and birth defects or other reproductive harm. For more information go to www.P65Warnings.ca.gov.

Threading

▲ WARNING

1. Take care when handling the blades.

- To prevent accidents and injuries, take special care when handling blades such as dies, reamers, pipe cutters and carbide cutters.

2. Do not put your hands or face near rotating parts when the machine is in use.

- You could get caught in rotating parts or hit by scrap, resulting in accident or injury.

3. Do not wear gloves when operating the machine.

- Gloves may get caught in rotating parts or blades, resulting in accident or injury.

4. Do not leave the machine while it is still rotating.

- Others may be injured.

5. If you accidentally drop or hit the machine, carefully check for damage, cracks, deformities or any abnormalities.

- If abnormalities are found, ask your distributor or our sales department for an inspection and/or repair.
- Continuing to use the machine when damaged will likely lead to mechanical problems, accident or injury.

6. Do not touch the dies or scrap just after threading.

- The dies and scrap can become very hot just after threading; touching them could burn or injure you.

7. Die head and dies

- Use the die head and dies that are appropriate for the type and diameter of pipe to be processed.
- When threading stainless steel pipes use pipes with a wall thickness equivalent to Schedule 40 or more.
- Make sure the die head is mounted correctly on the carriage. Be careful not to get your fingers caught.
- Before you start threading, set the die head in the threading position, switch ON, and check that the oil is flowing correctly over the dies. Failing to do so could result in an imperfect thread, damage to the machine, accident or injury.

8. Be sure to check the starting position before threading.

- When threading, start with the carriage to the right of the red line on the front support bar (as viewed from the working position).

If the carriage is not in the correct starting position, the die head will bang into the main unit while threading, causing mechanical problems, accident or injury.

9. Use the pipe support when threading long pipes.

- When threading long pipes, use a pipe support to prevent both vibration due to warping while the pipe is rotating and instability of the machine due to the weight of the workpiece.
- If a pipe support is not used, threading cannot be performed correctly and problems with the machine, accident or injury may occur.

10. Be sure to attach accessories according to the operation manual.

- Attaching accessories incorrectly may cause the machine to topple over resulting in accident or injury.

Reaming

▲ WARNING

The reamer blade is very sharp; to prevent injury, avoid touching it with bare hands.

Precautions

Cutting

- Using the Pipe Cutter

⚠ CAUTION

When cutting pipes, turn the cutter handle no faster than 1/2 rotation per rotation of the pipe.
- If the cutter handle is turned too quickly when engaging the pipe, it can distort the shape of the pipe and may not make a proper thread.

Handling pipe threading oil

⚠ WARNING

1. Wear goggles
 - Touching the eyes with oil may cause inflammation.
 - Emergency treatment : Wash eyes with clean water for about 15 minutes and seek medical attention.
2. Wear protective gloves.
 - If oil comes into contact with the skin, it may cause inflammation.
 - Emergency treatment : Carefully wash the affected part with soap and water.
3. Take care not to breathe in oil mist or steam.
 - Breathing in oil mist or steam may cause nausea.
 - Emergency treatment : Carry the person out into the fresh air, cover them with a blanket, keep them warm and relaxed, and seek medical attention.
4. Do not thin the oil or mix it with threading oil produced by other companies.
5. If water gets mixed in with the threading oil and the colour changes to a milky white or the oil deteriorates excessively resulting in a poor finish, change to fresh oil promptly.
6. Do not drink the oil
 - Drinking the oil may cause diarrhea or vomiting
 - Emergency treatment : Seek medical attention immediately, without forcing the person to vomit.
7. Do not place the oil where it is easily reached by small children.
8. Be especially careful of fire.
9. Storage
 - Always close the lid after use to prevent the oil from being contaminated by dust, water or other foreign bodies.
 - Store in a dark place away from direct sunlight.

When using threading oil for water mains pipes and water-immiscible cutting fluid for threading

⚠ CAUTION

1. Handling waste oil and waste cans
 - Handle materials according to local laws and regulations regarding waste disposal and cleaning.
 - If uncertain, consult your distributor or our sales department.
2. Drums (200L)
 - To prevent them from bursting, do not apply pressure to empty drums.
 - Do not weld, heat, drill or cut the drums or they may burst into fire from the residue they contain.

When using threading oil for stainless steel pipes

⚠ WARNING

1. Do not burn off the oil.
 - Oil contains chlorine compounds and generates toxic gas when burnt.
 - In the case of an emergency in which someone has inhaled such toxic gases, carry the affected person out into the fresh air and seek medical attention.
2. Disposal of waste oil and cans.
 - Follow all laws and regulations related to the disposal and cleaning of waste materials. When uncertain, consult your distributor or our sales department.

Main Parts, Specifications, Standard Accessories, Usage

Main parts 8090

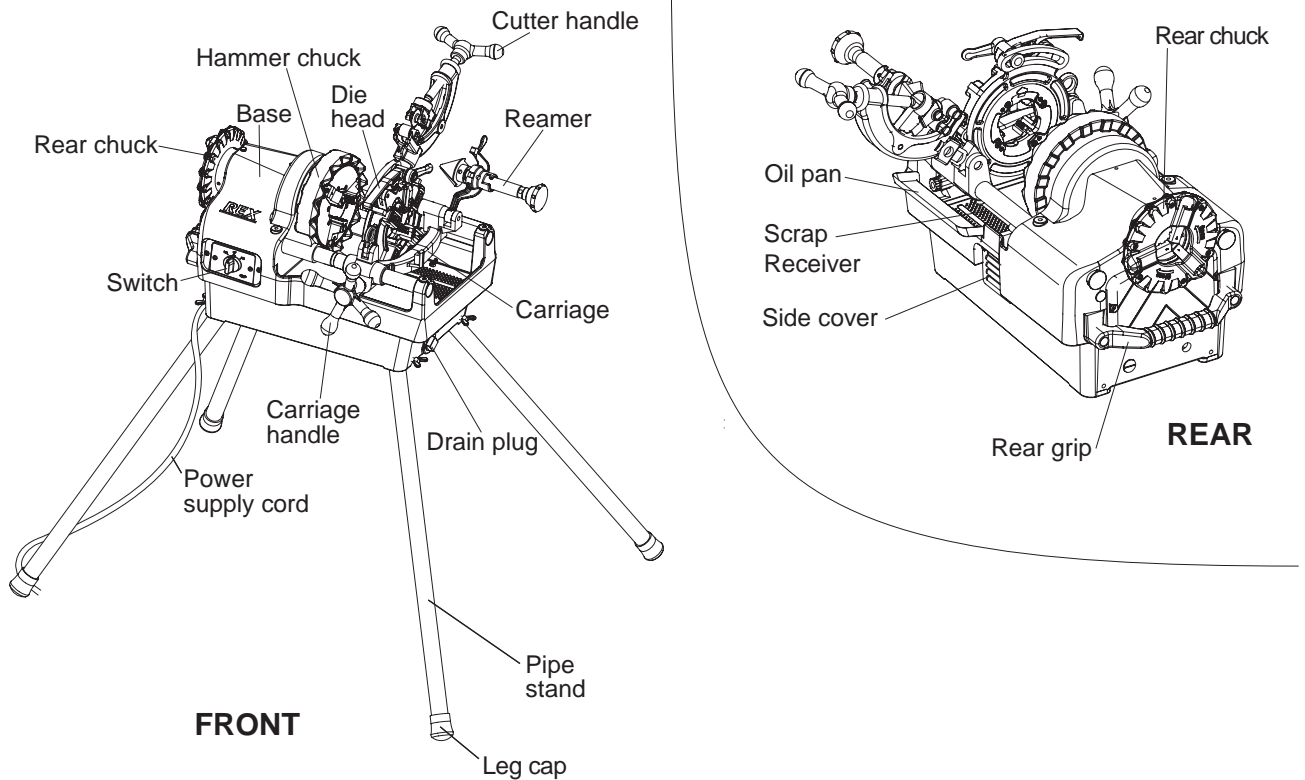

Fig. 1

Specifications

| | 8090 |
|----------------------|---|
| Threading capacity | 1/2" (15A) - 2"(50A) |
| Type of thread | Standard Taper Pipe Thread |
| Voltage | 110 - 120V, 220 - 230V |
| Motor | Single phase 700W series motor |
| Rotation speed | 39 r.p.m. (unloaded) |
| Net weight (kg/lbs) | 48 Kg / 106 lbs |
| Dimensions (mm/inch) | 700 (L) X 440(W) X 408(H) / 281/2"(L) X 16"(W) X 17"(H) |
| Chuck type | K-type chuck, S-type chuck jaw insert |

Table 1

Standard Accessories

| | 8090 |
|------------------------|--|
| Die head | NV-auto 1/2 - 2" |
| Dies | 1/2 - 3/4", 1 - 2" One set each |
| Threading oil | Thread Master |
| Pipe stands / leg caps | 4/4 *Model without pipe stand and leg cap also available |
| Hexagonal keys | 3, 4, 5, 6 mm 4 |
| Carbon brushes | Spare carbon brushes 1 set |

Table 2

Usage: Pipes, with our optional dies and die heads for bolt, threading steel round bars.

Getting Ready (Transportation / Machine set up / Thread cutting oil / Attaching the die head)

1. Transportation

When moving or transporting the machine, remove the oil pan. There is no need to drain off the cutting oil in the tank. (Fig. 2)

- NV-auto die head, Self-opening die head
Before moving the machine, chuck a piece of pipe securely and fix the pipe with the cutter.
- Manual open die head
Chuck a piece of pipe securely, loosen the lever nut on the die head and open the dies. (So that the dies do not drop out, place the eccentric handle in the thread cutting position.) Lower the pipe cutter, fix the pipe with the cutter rollers and blade, and then move the machine.

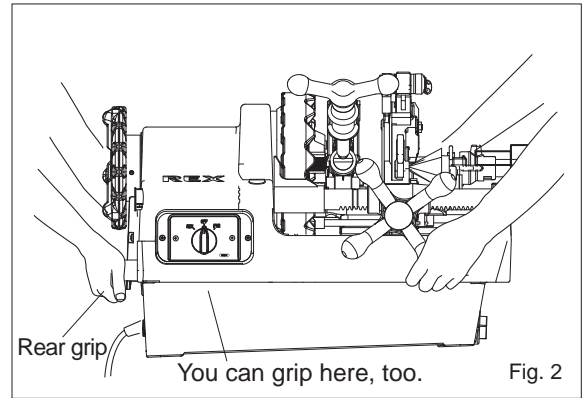

Fig. 2

2. Machine set up

When setting up the machine, the legs should be adjusted with the rear chuck higher than the hammer chuck. (Fig. 3)
(Even when using on a flat surface be sure to set up the machine with the rear chuck raised a little)

⚠ WARNING

If the rear chuck is too low, oil will flow out of the pipe, making the floor dirty and wasting oil.

Once the machine is set up, be sure to place the oil pan in its correct position.

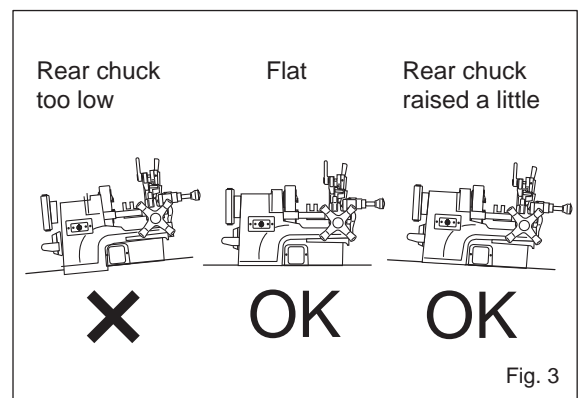

Fig. 3

3. Thread cutting oil

Fill the tank with the cutting oil that is supplied with the machine. Use only genuine WHEELER REX threading cutting oil. (Fig. 4)

- 60601 1 Gallon Thread master oil
- 60602 5 Gallon Thread master oil

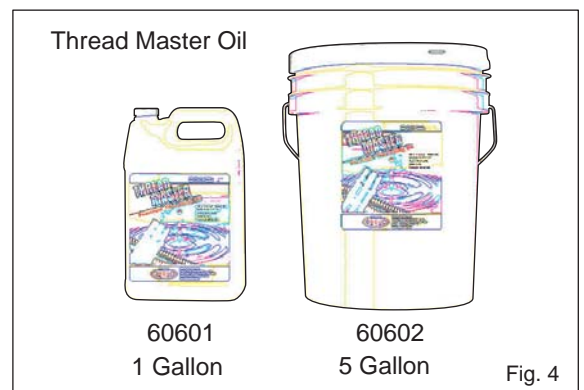

Fig. 4

4. Attaching the die head

Attach the die head that matches the size of pipe to be threaded to the machine. (Fig. 5)

Attach the die head to the machine

- Align the die head post to the carriage fitting hole, and push it until it contacts the carriage while moving the die head up and down a little.
- Lower the die head and check it is positioned correctly.

* Remove the die head by following the above in the reverse order.

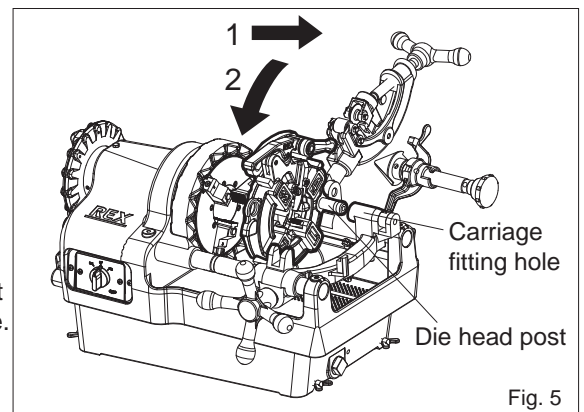

Fig. 5

5. Operating the Die Head

Manual-open die head

(There is no need to remove the die head from the machine)

Removing the dies

- Knock the eccentric handle to the right, loosen the lever nut and push the eccentric handle over to the far left. (Fig. 6)
- In this position, dies No. 3 and No. 4 can then be removed.
- Raise the die head and you can remove dies No. 1 and No. 2.

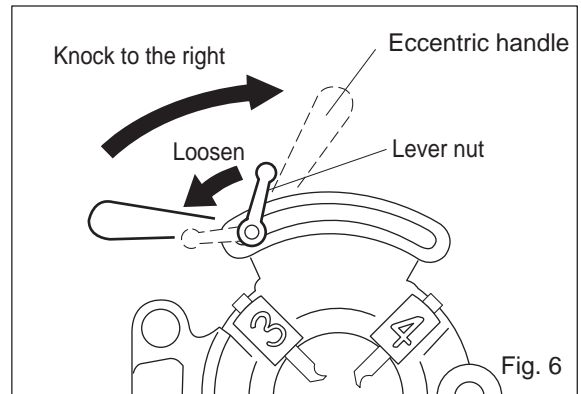

Replacing the dies

- Ensure the number on the dies corresponds with the number of the slot on the die head. Insert each die until the notch is engaged. (Fig. 7)
- Pull the eccentric handle back in the opposite direction, left of the arrow; (Fig. 6) The dies will move towards the centre of die head.
- * If the eccentric handle does not move into position properly, move the dies up and down a little while pushing and pulling the eccentric handle gently and try again .
- * Dies are made as a matched set of four, so be sure to use them as such and replace them all at the same time. Do not attempt to replace just one or two of the set, as cutting will be adversely affected.

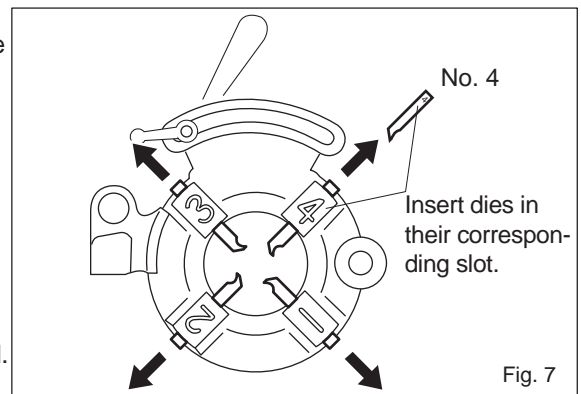

NV-auto Die Head

(There is no need to remove the die head from the machine.)

Removing the dies

- Open the die head. (Fig. 8)
- (i.e. Pull the open lever as shown by the arrow marked "Open")
- Loosen the lever nut (Fig. 8), pull the cam plate as far as it will go in the direction of the arrow, and lightly tighten the lever nut. Dies No. 3 and No. 4 can be then be removed. (Fig. 9)
- Raise the die head and you can remove dies No. 1 and No. 2.

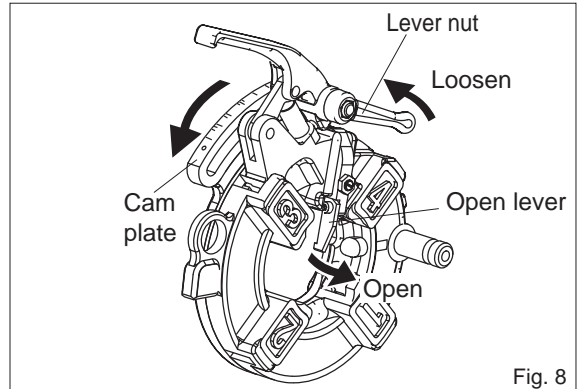

Replacing the dies

- Match the number on the die to the corresponding number on the die head.
- Insert the die until the notch clicks into position.
- Push the cam plate back; the dies will move towards the centre of the die head.
- * If the dies do not move into position properly, move them up and down a little and try again.
- * Dies are made as a matched set of four, so be sure to use them as such and replace them all at the same time.
- Do not attempt to replace just one or two of the set, as cutting will be adversely affected.

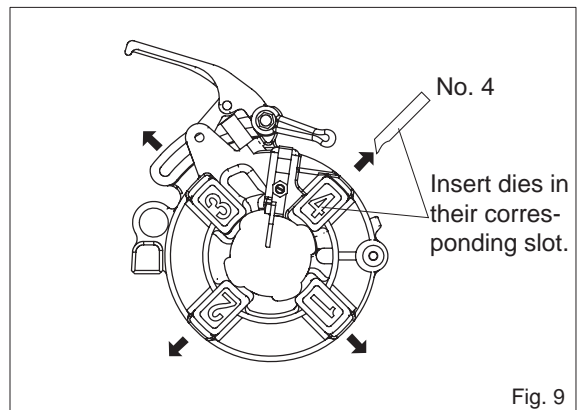

Getting Ready (Setting up the pipe / Removing the pipe / Power supply)

6. Setting up the pipe / Removing the pipe

⚠ WARNING

- Do not install or remove a pipe when the machine is moving, such as when operating the machine or just after you switch it off. If you do, you may get entangled, leading to accident or injury. Start operation after you make sure the machine has come to a complete standstill.
- When installing or removing the pipe, remove the plug from the power outlet or the machine could suddenly start operating leading to injury or accident.

- Open the hammer chuck and rear chuck wider than the size of the pipe to be threaded and insert the pipe from the rear chuck side where possible. (Fig. 10) (In the case of a short pipe, insert a pipe from the chuck side.)

- Close the rear chuck and, holding the pipe in your right hand, close the hammer chuck with your left hand to place a grip lightly on the pipe and make sure the chuck jaw inserts engage the pipe properly. Pull the hand-wheel sharply towards you to lock.

- A sharp jerk in the opposite direction will release the pipe once you have finished threading. Next, remove the pipe after releasing the rear chuck.

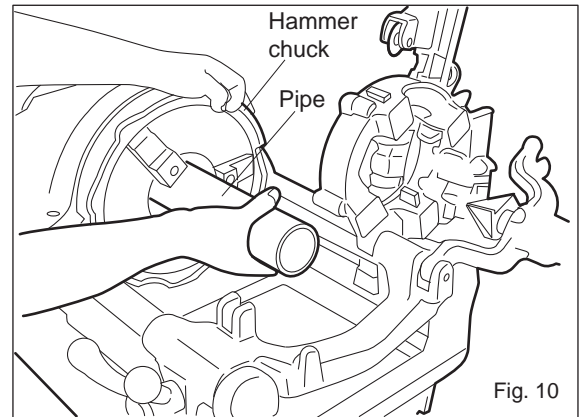

Fig. 10

Suggestions for short pipes

- Lightly grip the pipe with the chuck, gently engage the dies with the end of the pipe to be threaded, and then tighten the hammer chuck again. (Fig. 11)

Note: Chuck the pipe with the pipe protruding at least $3\frac{1}{2}$ from the edge of the chuck jaw insert. (Fig. 11)

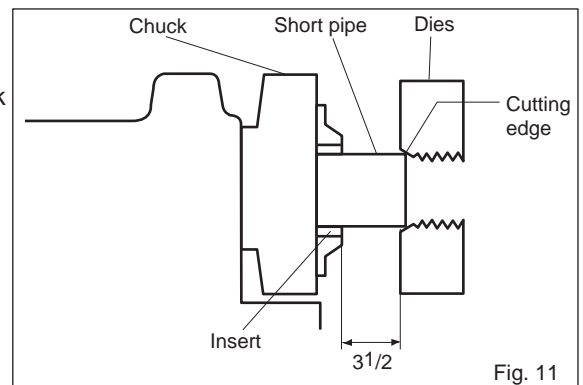

Fig. 11

Use the Model :
WH #850, 851,
Folding tripod pipe supports.

Keeps long pipes stable.

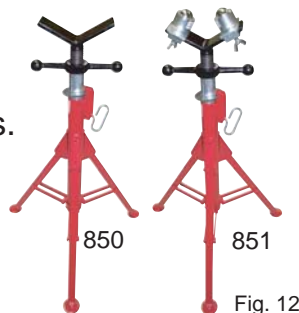

Fig. 12

⚠ WARNING

Not using a pipe support may result in irregular threads, damage to the machine and/or accident or injury.

7. Power supply

Before using the unit, check the voltage on the nameplate.

Use only an AC power supply. If an extension cord is used, it must be as short as possible and of sufficient capacity for the power supplied (at least 2mm^2 cable, 20A for 110-120V and 10A for 220-230V). (Fig. 13)

⚠ WARNING

- Before connecting the plug to the socket, check that the machine switch is turned OFF to prevent abrupt movements that could lead to accident or injury.
- When you use a 110 - 120V power supply, ensure it is grounded or you may get an electric shock. If the power socket is already grounded, first remove the supplied adapter with the ground.

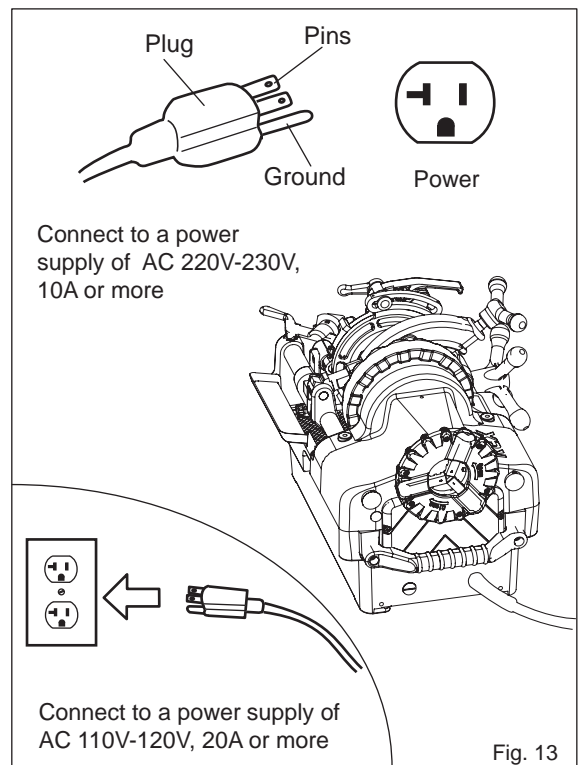

Fig. 13

8. Checks before starting

⚠ WARNING

Carry out the following checks before starting to cut or thread pipes. Should any problems arise, refer to "Troubleshooting" at the end of this manual and follow the appropriate instructions. Continuing to use the machine when a problem has arisen can lead to accident or injury.

1. Turn on the machine to set the main shaft in motion. (Fig. 14)
 - Check there are no abnormal sounds or odours coming from the motor.
 - Check the pipe you installed does not vibrate abnormally. If it does, install it again.
 - Check that cutting oil flows as it should from the die head. Confirm that there is at least 1 liter of cutting oil in the tank. (tank capacity:1.3L)
2. Allow the machine to rotate without any load for several minutes.
 - Check the motor does not become abnormally hot, etc.
3. Turn the machine off and allow it to stop rotating.
 - Check that the motor stops rotating right away. The unit uses a motor equipped with brakes for improved safety. Make sure you read and understand the points below relating to the use and performance of the brake system.

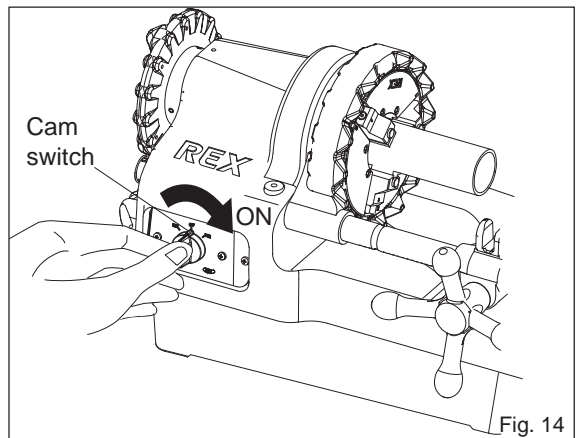

9. Cutting pipe

- Raise the die head and reamer.
 - Position the pipe so that it is ready for cutting and fasten the pipe securely with the hammer chuck.
 - Open the pipe cutter wider than the diameter of the pipe, lower it into position and turn the cutter handle, bringing the cutter close to the position where the blade and roller lightly press against the pipe.
 - Switch the machine on and turn the cutter handle up to 1/2 a turn for each rotation of the pipe. (Fig. 15)
- *Note: If the cutter handle is turned too quickly, it will affect the shape and finish of the thread.

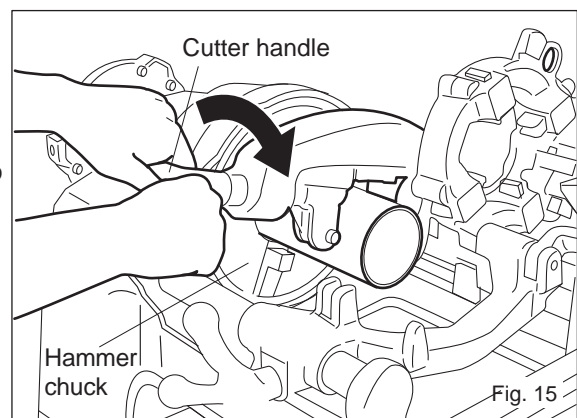

⚠ CAUTION

Be sure to position the cutter correctly before the pipe starts rotating. If it is not in the correct position it could damage the pipe or the machine.

Special precautions when you cut a pipe with another cutter

We strongly recommend that only the pipe cutter attached to the machine be used to cut pipes.

If another cutter is used, ensure that the pipe end is at right angles to the axis of the pipe. (Fig. 16-A)

If the pipe is not square on, as in Fig. 16-B and C, threads may be defective. B and C may be the result of the following:

Fig. 16-B

- The bearing or chucking of the cutter is unstable.
- When a grinder is used with excessive force (especially in the case of large diameter pipes.)
- When the pipe is engaged at an angle when cutting.

Fig. 16C

- When you have cut a large diameter pipe 2 or 3 times with a small grinder.

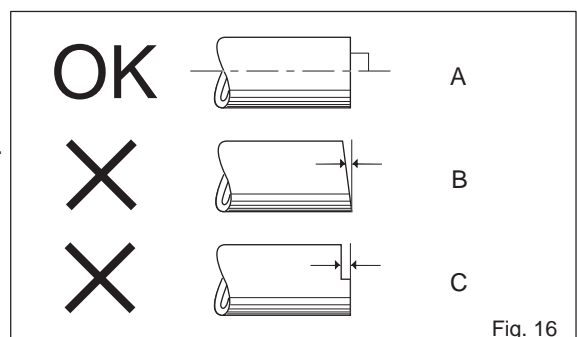

⚠ CAUTION

If the end of the pipe is slanted (Fig. 16-B) or has steps in it (Fig. 16-C), it is not only impossible to make a perfect thread, but may even result in damage to the machine, accident or injury.

Getting Ready (Reaming / Points to watch when threading)

10. Reaming

- After cutting the pipe with the pipe cutter, be sure to use the reamer to chamfer the inside of the pipe before making a thread. (Figs. 17, 18)
- Lift the die head and cutter out of the way.

Reamers with a shaft

- Lower the reamer arm and set it in position on the carriage, then push the reamer knob toward the pipe. (Fig. 17-1)
- *Note: Reaming is possible without pushing the shaft when a pipe is chucked long enough from the chuck.
- Lock the reamer in position by turning the reamer handle counter-clockwise. (Fig. 17-2)
- Turn the machine on to start the pipe rotating. Then turn the carriage handle to the right to move the reamer forward to engage the pipe. Allow the pipe to rotate at least 1/2 a turn, then remove the reamer from the pipe. That completes the reaming process. (Fig. 18)

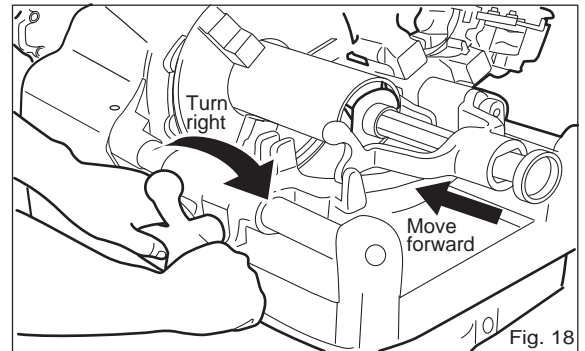
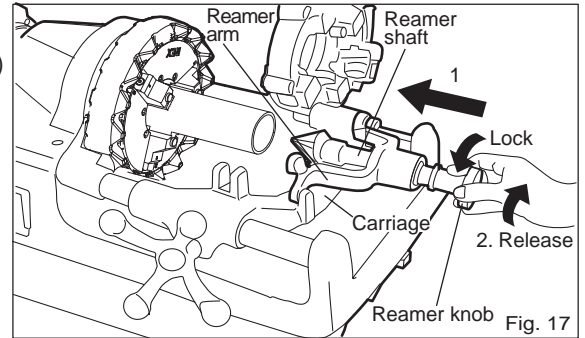

CAUTION

- Do not use excessive force when pressing the reamer against the pipe as this may scratch the pipe or even damage the machine.
- The reamer blade is extremely sharp. NEVER touch it with your bare hands as you could be seriously injured.

Points to watch when threading

Manual-open Die Head

1. Before adjusting the size of the thread to be cut, bring the eccentric handle towards you, until it is in the position indicated. (Fig. 19-1)
2. Tighten the lever nut securely by hand.
3. Thread size can be simply adjusted with the lever nut. Move it towards you to increase, and away to decrease the thread size. (Fig. 19-2)

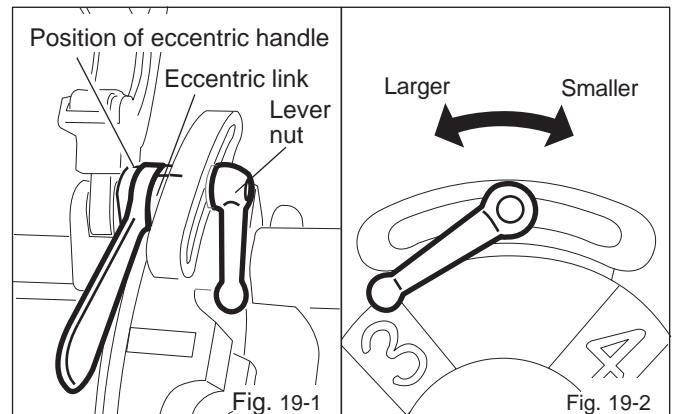

NV-auto Die Head

1. When setting the size of the thread to be cut, first lower the Open lever until it is in the Set position and then match the mark on the cam plate fixing pin with the size plate according to the pipe size scale on the die head. (Fig. 20)
2. Tighten the lever nut securely by hand.
3. To adjust the thread size, turn the mark on the cam plate fixing pin closer towards you from the line on the size mark to make it larger, and in the opposite direction to make it smaller.

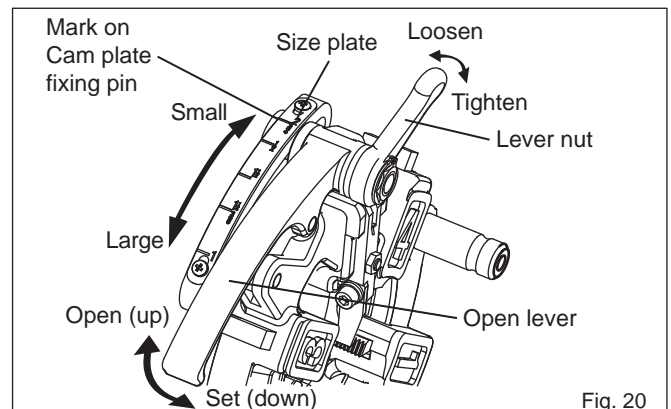

11. Making threads (Optional Manual-open Die Head)

When using a Manual-open Die Head (1/2 - 2"), check that the die head and dies you are using are suitable for the pipe you are working on.

⚠ CAUTION

Start the thread cutting process with the carriage to the right of the red line on the front support bar. Failure to do so could lead to accident or damage to the unit.

- To match the size of the thread, align the scale on the Eccentric link (Fig. 19-1) with the thread size on the size scale on the die head, and then tighten and fix the lever nut in position (Fig. 21).
- Turn the machine on and oil will automatically flow from the die head.
- Turn the carriage handle to the right to engage the pipe with the dies.
Cut 3 or 4 threads and threading will then be performed automatically. The unit uses a series motor whose rotation speed automatically varies according to the load. (Fig. 22)
- When the thread has been cut to the prescribed dimensions, slowly raise the eccentric handle in the direction of the arrow and release the dies to complete the threading process.
(Note: If you release the dies too abruptly, it may result in an imperfect finish such as a step-edged thread). (Fig. 23-1)
- Finally, complete the process by releasing the die head from the pipe by turning the carriage handle to the left. If you place the die head in the raised position, the flow of oil will stop. (Fig. 23-2)

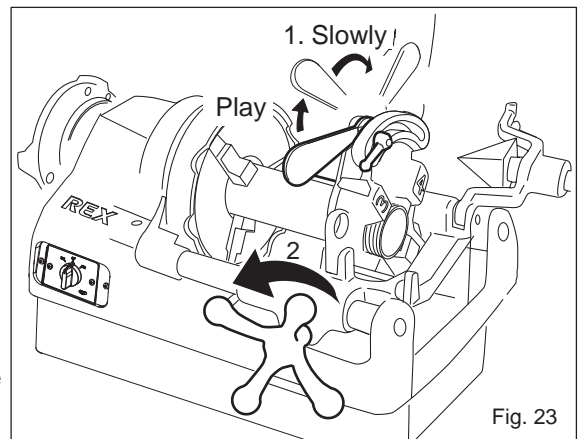
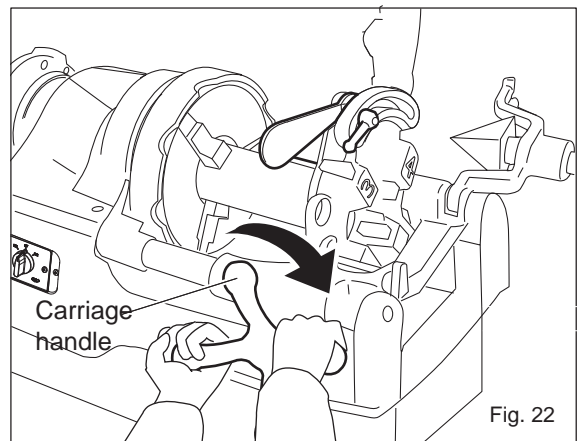
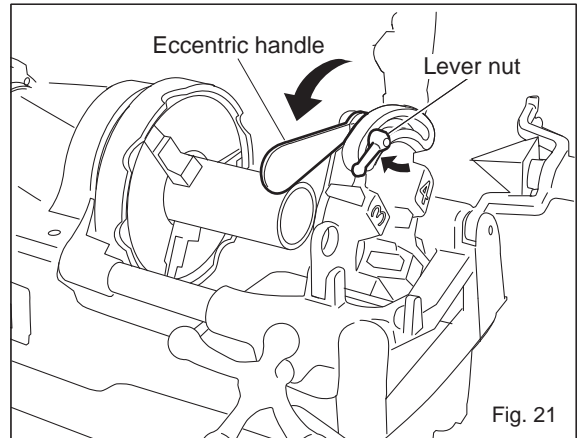

12. Adjusting the oil flow

You can adjust the oil flow from the die head.

- With the die head in threading mode, remove the oil pan and check the discharge of the oil.
- Turn the relief valve to adjust to the most suitable amount of oil needed. (Fig. 24)

* Depending on the load when threading, the amount of oil will vary according to the speed the machine rotates.

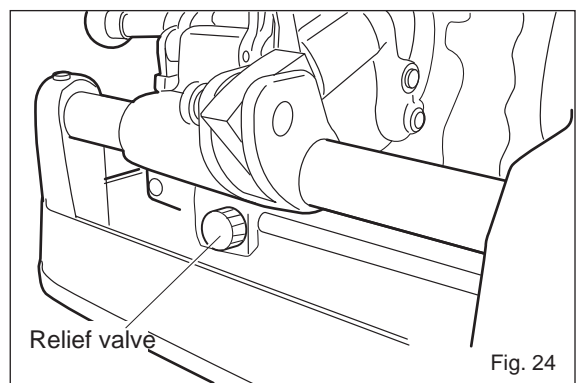

Operation Guide (Making threads NV-auto Die Head)

13. Making threads (NV-auto Die Head)

The NP/NR50A Series comes with the Manual, NV-auto, or Uni-auto die head (1/2 - 2") and 2 sets of dies (1/2 - 3/4")(1 - 2") as standard accessories.

Check that the dies you use match the size of pipe you are working on.

⚠ CAUTION

To avoid accident or injury, always start the thread cutting process with the carriage to the right of the red line on the front support bar.

Loosen the lever nut on the die head and match the marking on the cam plate fixing pin with the pipe size on the size plate; then retighten the lever nut. (Fig. 25)

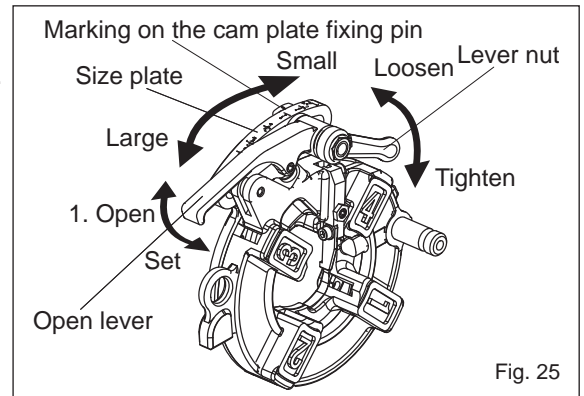

Fig. 25

Press down on the Open lever to put it into the 'Set' position. (Fig. 26)

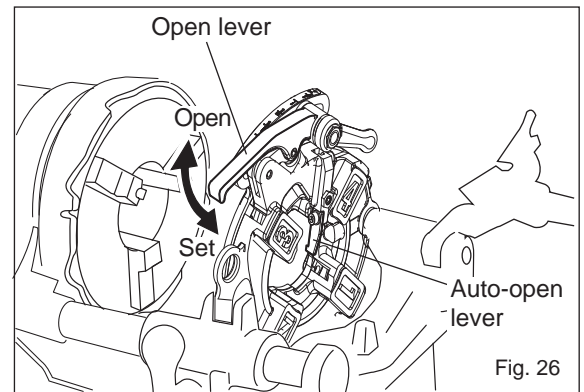

Fig. 26

Switch the machine on and oil will start flowing automatically from the die head.

Turn the carriage handle to the right to engage the pipe with the dies. Cut 3 or 4 threads and threading will then be performed automatically. (Fig. 27)

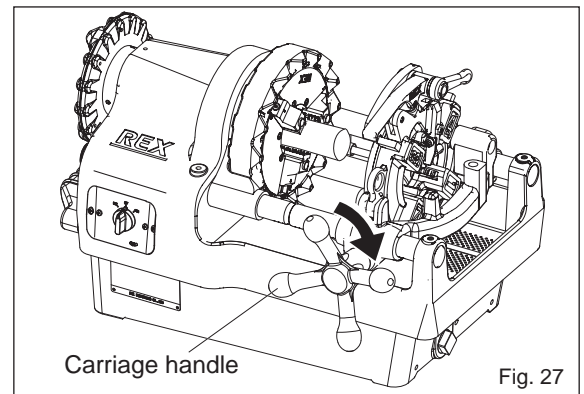

Fig. 27

When the prescribed length of thread has been cut, the dies will automatically be released by the auto-open lever.

Finally, release the die head from the pipe by turning the carriage handle to the left.

You can make shorter threads or any length of parallel threads, bolts etc., if you raise the open lever at the length you want. When threading longer parallel threads, remove it as described below.

If the die head does not open automatically for some reason, such as scrap preventing it from opening, you can open the die head by raising the open lever. (Fig. 25-1)

* Make sure the die head and dies are appropriate for the type of thread that you wish to make; for example, threads or bolts etc.

1. Removing the auto-open lever. (Fig. 28-1)

Loosen the hex-socket cap screw (M6 x 12) and remove the auto-open lever together with the washer and the spring washer.

* Make sure you do not lose any of the parts you remove. If you do, you will not be able to use the auto-opening function to cut threads of a regular length.

2. Resetting for regular tapered threading. (Fig. 28-2)

Adjust thread length by sliding the auto-open lever forward or backward.

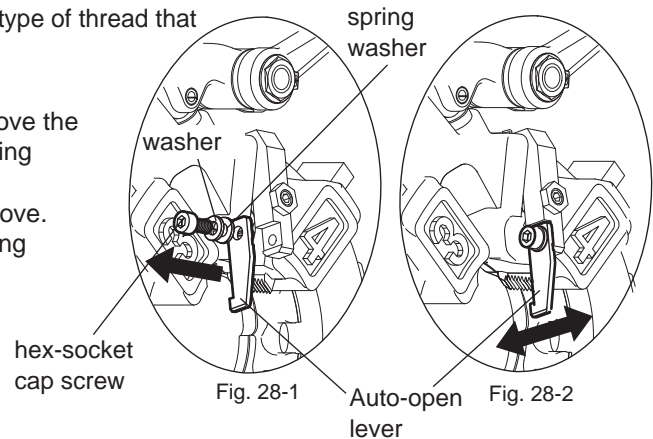

⚠ WARNING

Threads may be affected by the condition of the dies (blades), cutting oil etc., so be sure to use a thread gauge to check the thread. This is especially important after you have changed the die set.

14. Measuring threads with a gauge

Confirming the thread diameter

- Use a thread gauge to confirm the diameter is as it should be.

Thread gauge

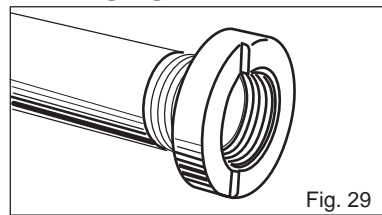

Fig. 29

Other pipe thread gauges

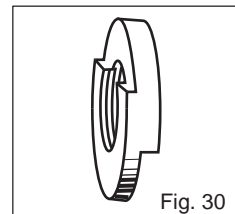

Fig. 30

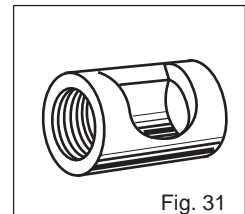

Fig. 31

Unacceptable threads

- Irregular shaped threads (Fig. 32 - 1)
Recognising irregular shaped threads
 - Visually inspect the thread after wiping off any oil or dirt with a rag; you will find a wave-like formation.
 - Gently check the surface of the thread with your fingers, feeling for any irregularity.
 - Check if bits of scrap are produced when cutting.
- The diameter of the thread is too small or too large (Fig. 32 - 2)
Check with a thread gauge
- Distorted threads (in the case of manual die heads) Fig. 32 - 3)
When cutting threads that are wider than the width of the dies, you can gradually open up the eccentric handle; but then if you leave the eccentric handle in the same position and cut a thread longer than the width of the dies, the taper will remain the same width as the die and the rest of the thread will be straight.
- Threads are too small (Fig. 32 - 4)
- The thread is chipped (Fig. 32 - 5)
- Thread with uneven thickness (Fig. 32 - 6)

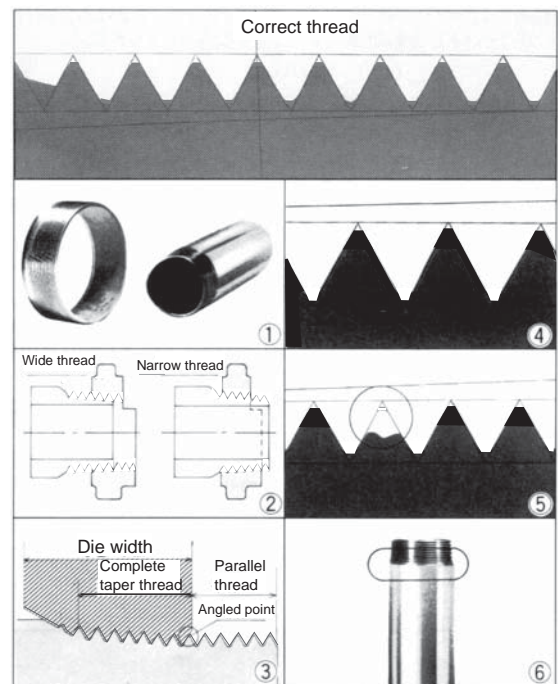

Fig. 32

Precautions when threading

- Care when the dies come into contact with the pipe (Fig. 25)

Engage the cutting edge of the dies very lightly with the end of the pipe. Bringing the dies too forcefully into contact with the pipe will result in damage to the dies and shorten their working life. Once the dies engage the end of the pipe, apply light pressure to the carriage handle in a clockwise direction and then gradually increase the pressure. As the dies cut into the pipe, it is no longer necessary to apply pressure to the carriage handle as the carriage will move on its own.

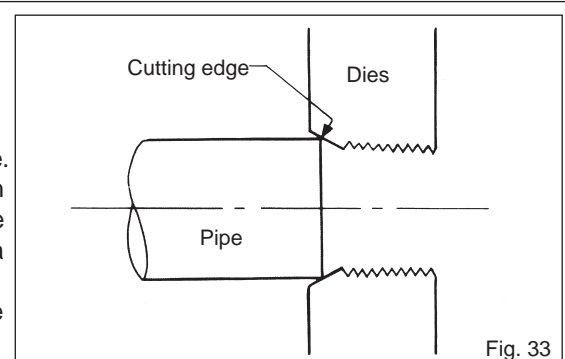

Fig. 33

Optional Accessories

Die head

| | | |
|-----------------------|------------------------------------|---|
| Manual DH | For Steel pipes and Bolts | 1/4 - 3/8 + W5/16 - 7/8, 1/2 - 1 1/2 + W1 - 1 1/4 |
| | For Bolts | UNC5/16 - 2, M8 - 52 |
| | For Conduits (Thicker, Thinner) | PF16 - 54 + C19 - 51 |
| Self-opening Die Head | | 1/2 - 3/4, 1 - 2 |

Dies

Table 3

| | | | |
|-----------------------|--------|-----------------|--|
| For Steel Pipes | BSPT | Alloy | 1/4 - 3/8, 1/2 - 3/4, 1 - 2 |
| | | HSS | 1/4 - 3/8, 1/2 - 3/4, 1 - 2 |
| | NPT | Alloy | 1/4 - 3/8, 1/2 - 3/4, 1 - 2 |
| | | HSS | 1/4 - 3/8, 1/2 - 3/4, 1 - 2 |
| For Conduit | | Thicker conduit | PF16 - 22, PF28 - 36, PF42 - 54, G(BSPP)1/2 - 3/4, G(BSPP)1 - 2 |
| | | Thinner conduit | C19 - 25, C31 - 51 |
| For Bolt | BSW | Alloy | W5/16, W3/8, W7/16, W1/2, W5/8, W3/4, W7/8, W1, W1 1/4 |
| | | HSS | |
| | UNC | | 5/16, 3/8, 7/16, 1/2, 9/16, 5/8, 3/4, 7/8, 1, 1 1/8, 1 1/4, 1 3/8, 1 3/4, 1 1/2, 2 |
| | Metric | Alloy | M8, M10, M12, M14 - 16, M18 - 22, M24 - 27, M30 - 33, M36 - 39, M42 - 45, M48 - 52 |
| HSS | | | |

Parts for Single layer plastic coated steel pipes

Table 4

| | |
|---------------|--------------|
| Cutter Roller | Roller Blade |
|---------------|--------------|

Table 5

Pipe support: WH #850, #851, Folding tripod pipe supports *See Pg. 8, Fig. 12

Thread cutting oil:

60601 (1 Gallon) : Thread master oil

60602 (5 Gallon) : Thread master oil

Nipple attachments

- REX Nipple Attachments are designed to be used together with our pipe threading machine to produce nipples easily.
- Refer to Minimum Length of Nipples (Table 6) to select the appropriate size.
- Refer to the Nipple Attachment Operation Manual for how to use nipple attachments.

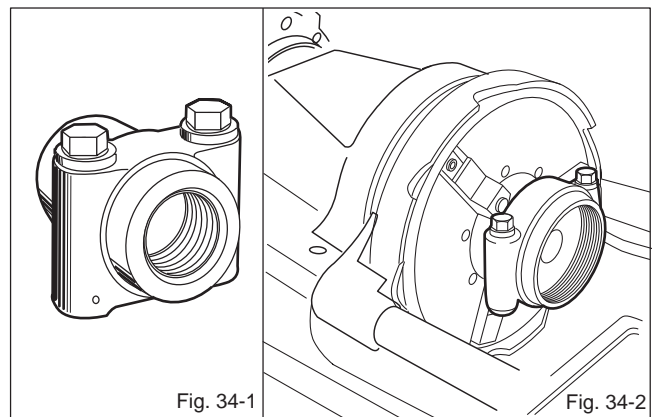

| | | | | | | |
|------|-----|-----|---|-------|-------|---|
| Size | 1/2 | 3/4 | 1 | 1 1/4 | 1 1/2 | 2 |
|------|-----|-----|---|-------|-------|---|

Table 6

Maintenance & Care

⚠ WARNING

- Before inspecting or performing maintenance on the unit, always set the switch to the OFF position and remove the plug from the power outlet.
If the unit is left plugged in, it may begin operating unexpectedly, resulting in injury.
- If you discover any problems during inspection or maintenance, look up the symptoms in the "Troubleshooting" table and take the appropriate action as noted in the table.
Continued use of the unit without correcting the problem may result in heat, smoke or fire and lead to accident or injury.

1. Grease, Oil

- Greasing the main shaft bearing.
Be sure to apply grease to the main shafts and bearings about once a month. (Fig. 35 - 1)
- Oiling the pipe cutter
Before you operate the machine, be sure to maintain lubrication by applying spindle oil or machine oil to the thread on the cutter handle, roller shafts and blades once a day. (Fig. 35 - 2)

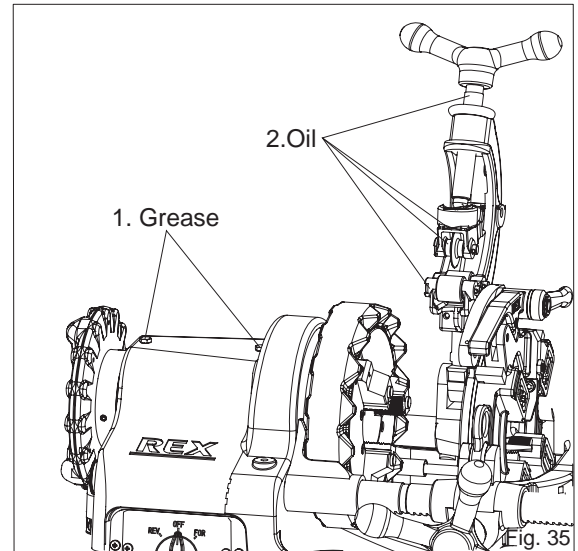

2. Replacing the carbon brushes

- To protect the motor, the unit is equipped with two auto-stop carbon brushes.
When these brushes get too worn, the motor will not operate even when the unit is turned on.
- Be sure to use WHEELER REX carbon brushes.
Using other brushes may damage the motor.

Replacing the carbon brushes

Ensure the plug has been removed from the power outlet.
Always replace both brushes at the same time.

- Replacing the carbon brush at the side (Fig. 36)
Remove the side cover from the side of the base, remove the carbon brush cap with a flathead screwdriver and replace the brush.
- Replacing the carbon brush at the bottom (Fig. 37)
Remove the bottom cover, remove the carbon brush cap with a flathead screwdriver and replace the brush.

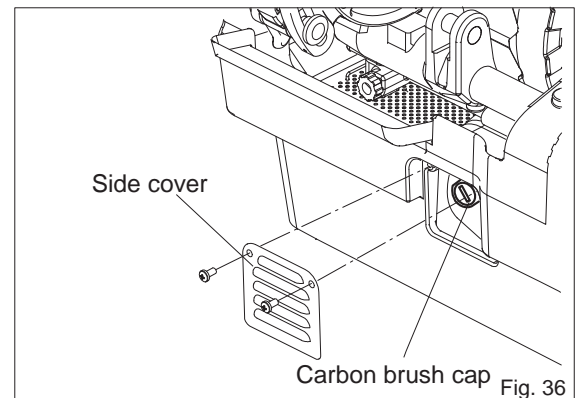

⚠ WARNING

- When replacing the carbon brushes, always make sure the unit is stable.
Trying to replace the brushes with the unit tilted is extremely dangerous, as the unit may fall over.
- Be sure to use WHEELER REX carbon brushes.
- Using other brushes may damage the motor or the machine, or cause accidents.

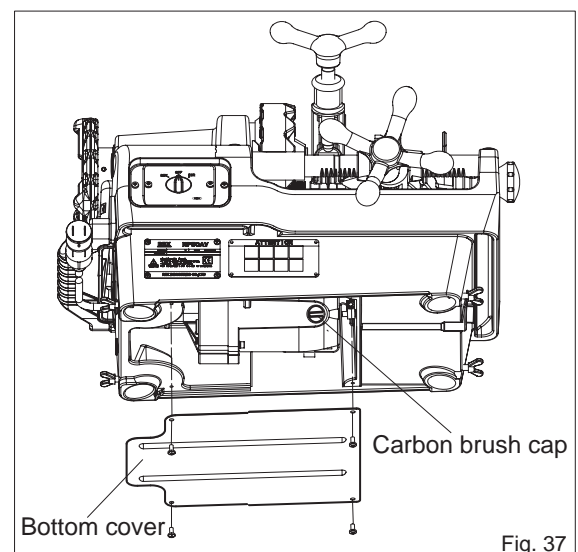

Maintenance & Care

3. Cleaning the oil tank

As tiny bits of scrap accumulate in the tank, be sure to clean it at least once a month. (Fig. 38)

- * There should be 1.3 liters of cutting oil in the tank.
- * Use WHEELER REX cutting oil only.

Cleaning the tank

- First loosen the wing bolt, and while holding onto the wire, lift up and remove the scrap tray.
- Remove the strainer by using a Phillips screwdriver to loosen the round head screw that fastens the oil tube to the strainer.
- Remove the drain plug and drain off the cutting oil.
- Replace the drain plug once all the scrap in the tank has been removed. Put the strainer back before replacing the cutting oil.

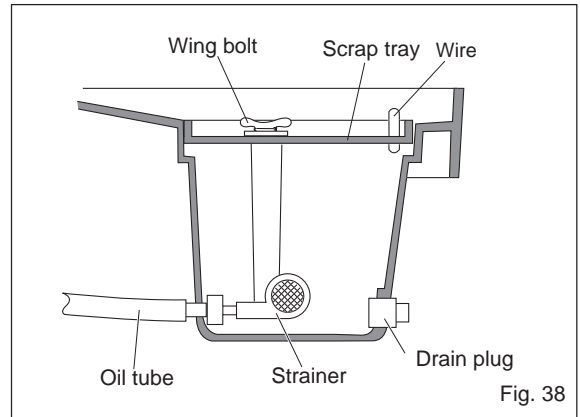

4. Replacing/Installing the chuck jaw set

As shown in Fig. 40, the insert set consists of 4 parts: the chuck jaw insert at one end of the chuck jaw, and the spring retainer, spring, and set screw at the other.

When changing the chuck jaw insert, turn the hand wheel so that the indent is directly over the chuck jaw and remove the set screw inside it.

Also, if the 6 bolts that fix the chuck in position come loose, it will affect thread cutting, so check regularly and tighten as needed.

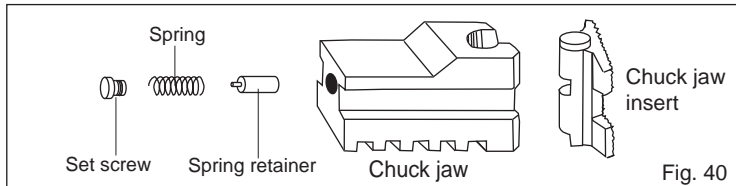
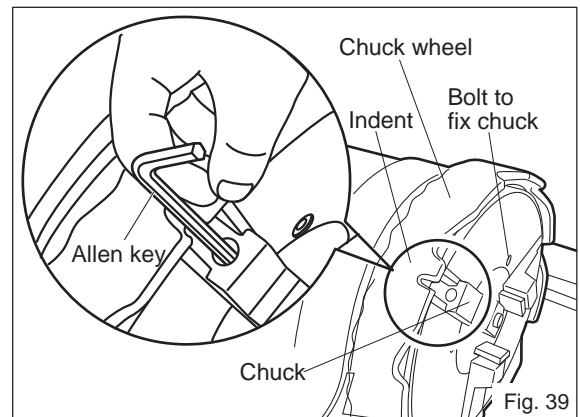

5. Wiring diagram

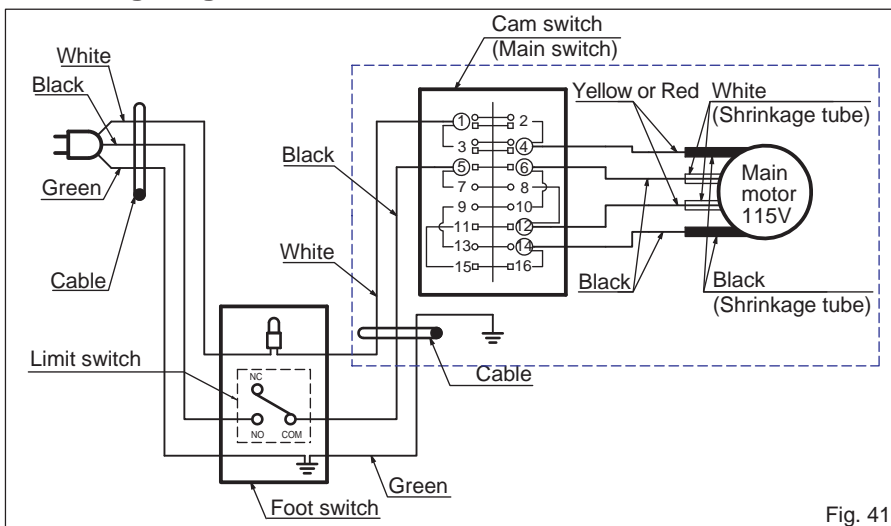

Service and Repairs

This machine is produced with great precision; therefore, should the machine fail to operate normally, do not repair it by yourself; contact your distributor or WHEELER REX.

If parts are required or if you have any questions, please contact us at your earliest convenience.

Servicing and Repairs

⚠ WARNING

- If the problem you have and the appropriate remedy are not shown in the table below, do not attempt to disassemble or repair the unit yourself.
- If the problem and remedy are not shown in the table, or if the table indicates that you should have the unit repaired or serviced, consult your distributor or WHEELER REX.
- If this product is repaired by someone who does not have the proper knowledge or technical skill to do so, the product may not operate properly, or an accident or injury may occur. In the event of a problem, always check the table before contacting WHEELER REX or your dealer.

Troubleshooting

| Problem | | Cause | Remedy |
|---|---------------------------|---|--|
| Machine does not operate properly when turned on. | The motor is not running. | The plug is disconnected. | Insert the plug into the power socket. |
| | | The carbon brushes are worn. | Replace with new ones according to the procedures on Pg. 15. |
| | | Voltage is low. | Check the voltage. (Pg. 8) |
| | | The motor is burned out. | Repairs are needed. |
| | | The switch is damaged. | Repairs are needed. |
| | The motor is running. | The gear is broken. | Repairs are needed. |
| Rotation of the main shaft is defective. | | Voltage is too low. | Check the voltage. (Pg. 8) |
| | | The motor is burned out. | Repairs are needed. |
| No oil flow. | | Amount of oil is too low. | Replenish oil. |
| | | Scrap clogging the flow. | Remove scrap in the oil tank. |
| | | The die head is not fitted correctly. | Fit the die head in the correct position. |
| Oil flows out of the back of the pipe. | | Rear chuck is set too low. | Raise the rear chuck. |
| Difficulty in attaching the die head. | | Scrap is in the way. | Remove scrap attached to the die head post and hole. |
| | | Die head is obstructed by cut-off pipe etc. on top of tank cover. | Remove the obstruction. |
| Moving parts do not move smoothly. | | Moving parts blocked by scrap. | Remove scrap. |
| Dies do not engage pipe correctly. | | The dies are worn. | Replace with new ones. |
| | | The dies are chipped. | Replace with new ones. |
| | | The dies are not inserted in the correct position. | Match the dies to the number on the die head. |
| Threading cannot be performed correctly. | Too Large /Small | The die head is not adjusted correctly. | Adjust the die head according to the procedures on Pgs. 10 - 13. |
| | | Too Long /Short | The die head is not adjusted correctly. |
| | | The dies are worn. | Replace with new ones. |
| | | The dies are chipped. | Replace with new ones. |
| | | Thread cutting oil has deteriorated. | Replace with new oil. |
| | | The dies are not inserted in the correct position. | Match the dies to the number on the die head. |

Table 7



WHEELER-REX

REX International U.S.A., Inc.

P.O.Box 688, 3744 Jefferson Road, Ashtabula, OH44005

Ph:440 - 998 - 2788 · Fax.: 440 - 992 - 2925

Toll Free: 1 - 800 - 321 - 7950

Website: www.wheelerrex.com

Manufacturer:

REX

REX INDUSTRIES CO., LTD.