

PipeMaster

Operation & Service Manual



Wheeler-Rex
Ashtabula, Ohio
Tel: 800-321-7950
Fax: 440-992-2925
wheeler@wheelerrex.com
www.wheelerrex.com



Choosing the Blade

There are three different types of blades



4616

6" Economy Diamond Blade

Can be used with or without coolant to make cuts on ductile iron and cast iron pipes. Economy blades come with arbor adapters and multiple drive lug holes to fit other competitors pipe cutters.

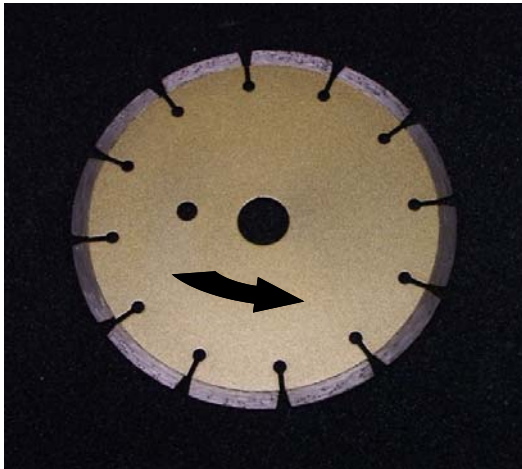

4606

6" Diamond Blade

Recommended to be used with coolant to make cuts on ductile iron and cast iron pipes.

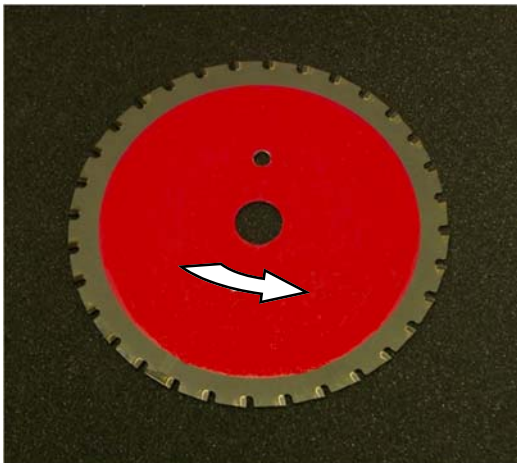

4706

6" Carbide Tipped Blade

Recommended to be used with coolant for cutting steel pipes.

Changing the Blade

1. Loosen the wing nut and remove coolant nozzle.



Wing Nut

2. Retract clips to open blade cover.



3. Using the two wrenches supplied, loosen the blade nut. Hold the blade arbor with small wrench and turn nut clockwise to remove blade.

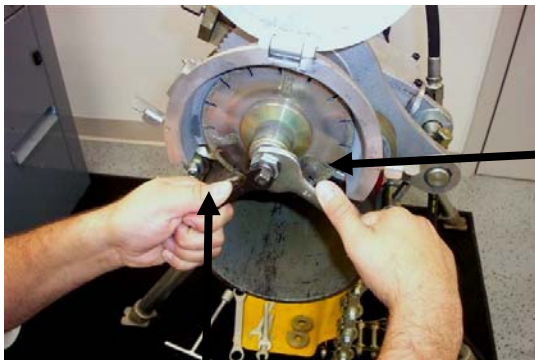

Large Wrench

Small Wrench

4. Remove nut, lock washer, washer, spacer and large washer to remove blade.



5. Note drive lug inserted in the blade as well as blade rotation direction. Some blades can be run in either direction, others cannot.

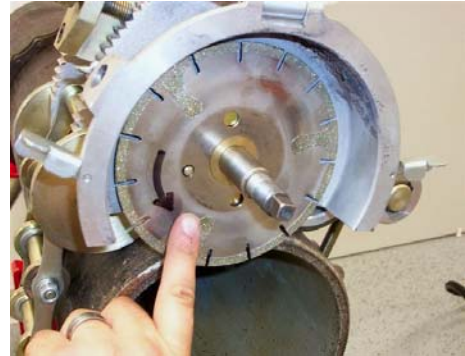

6. Installing blade repeat Steps 5 thru 2 in reverse order.

7. When replacing coolant nozzle into frame, make sure the outlet hole is facing the blade. And should be close to edge of blade.



PipeMaster Set Up

1. Select the correct idle wheels for the pipe size. For 8" and larger pipes, use the standard wheel (approx 2-1/8" diameter). For pipes under 8", use the larger wheels (approx 3-1/2", PN 700970)

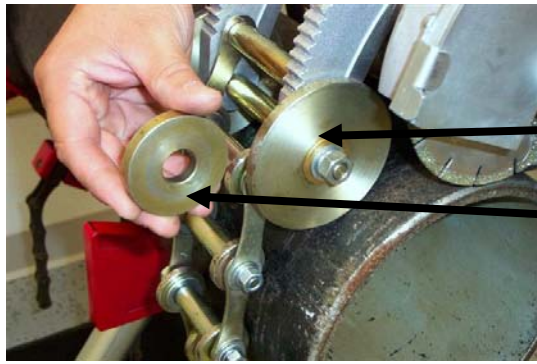

700970 Wheel

Standard Wheel

2. Clean pipe surface all around the pipe. Be sure that the blade has been raised to its highest position so that the blade will not be resting on the pipe. Place PipeMaster on the pipe to be cut. The PipeMaster should be set between the 12:00 and 1:00 position. Make sure all wheels are aligned and square to the pipe. This is done by checking to ensure that all four wheels are in solid contact with the pipe.

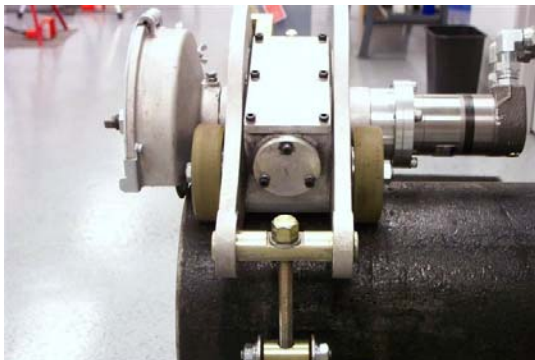

Correct Set Up

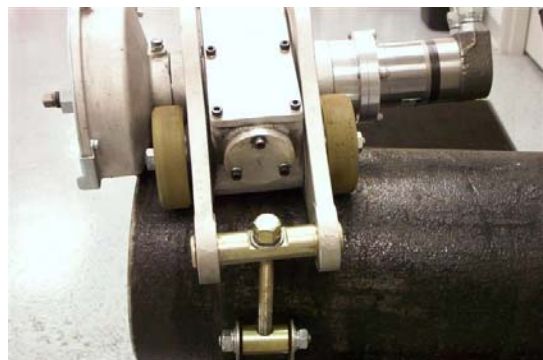

Incorrect Set Up

3. With open side of chain hook towards the pipe, attach the hook to the closest chain link. Some adjustment may need to take place with chain tension screw in order to catch the nearest link. Excess chain can simply hang. If there is too much excess chain, links can be taken off and stored.



4. Tighten chain tension screw with T-Handle wrench. The rubber coated drive wheels should be snug to the pipe. Screw tension is critical. Too much tension will cause the wheels to “smash” against the pipe and may impact the performance of the PipeMaster. Having the tension too loose will keep the PipeMaster from “climbing” back up the pipe to finish the cut. Prior to cutting make sure the pipe is clean.

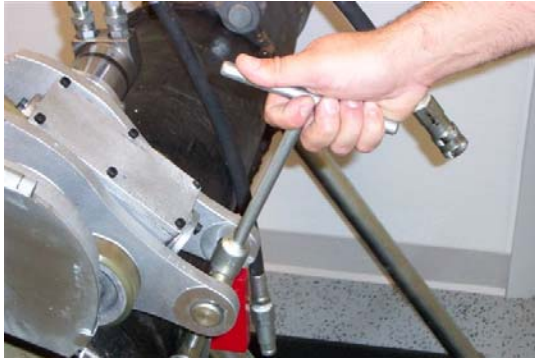

Too much tension on the chain



Correct tension on the chain

5. Check the blade guard screw and jam nut for proper tightness. Guard should not turn when the PipeMaster is attached to the pipe.

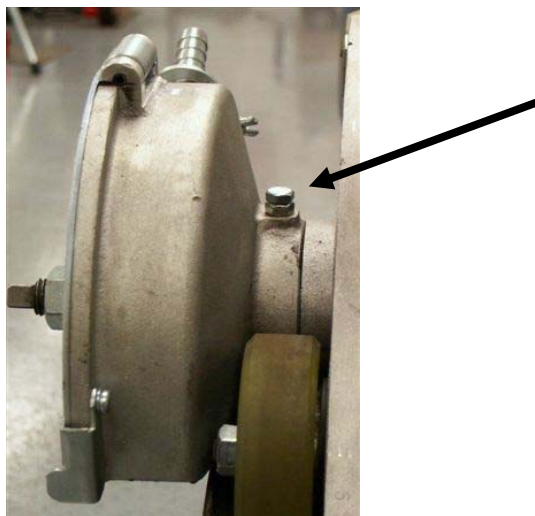

Connecting the PipeMaster to the Power Pack

1. There are two hydraulic lines with quick disconnects (one male and one female) located on both the PipeMaster. The Power Pack is equipped with a manifold where the hydraulic quick disconnects (one male and one female) are located.



Female

Male

2. Connect hydraulic lines between PipeMaster and Power Pack



Male & Female Quick Disconnect



Lines attached to PipeMaster



Lines being attached to the Power Pack



Lines attached to the Power Pack

Operating the Power Pack

1. Remove pipe plug (using a hex wrench) from the hydraulic tank and replace with breather cap supplied with Power Pack. The Power Pack is shipped with this plug to keep the hydraulic oil from spilling. The Power Pack will not meet its peak performance if the shipping plug has not been removed.

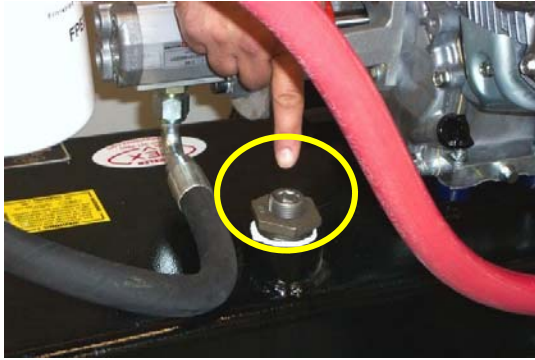

Pipe Plug



Breather Cap

2. Make sure to check the motor oil level and gas prior to starting.
3. Turn engine switch to the "ON" position.
4. Turn the gas switch to the "ON" position.
5. Turn the choke to the "ON" position.
6. Make sure the manifold is in the "OFF" position. Lever should be horizontal. Power Pack will not start with the valve in the "ON" position.

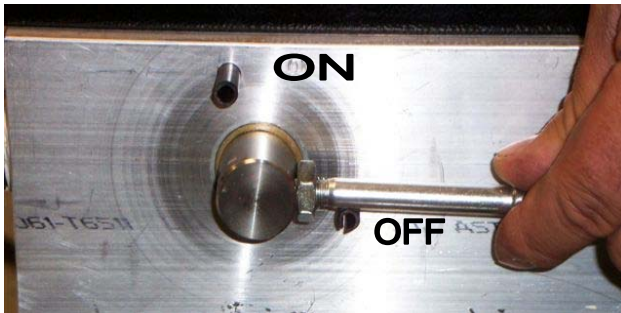

7. Start the engine, let it warm up for One (1) to Two (2) minutes, then set the throttle to the "Fast" position.

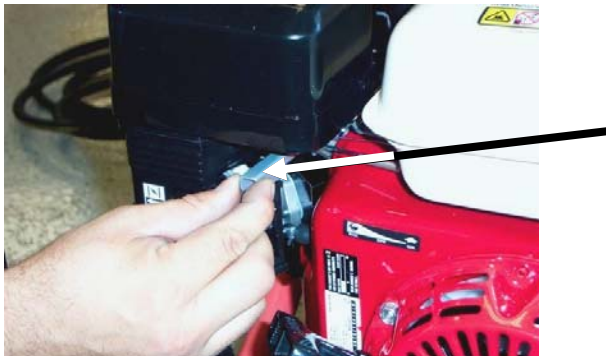

Preparing for the Cut

1. Check the PipeMaster “Feed Control Switch”. It should be in the “OFF” (horizontal) position.



2. Make sure there is a minimum of 8” clearance around all of the pipe you are cutting.

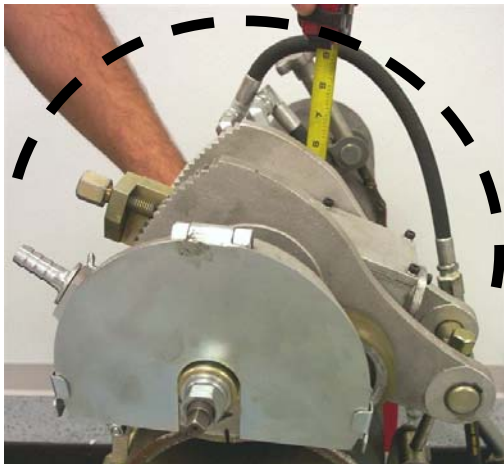

3. Check all hydraulic hose and connections. Make sure that they are free and that there is enough slack to travel around the pipe.



4. Turn the hydraulic manifold to the "ON" (vertical position). PipeMaster blade will now start spinning.

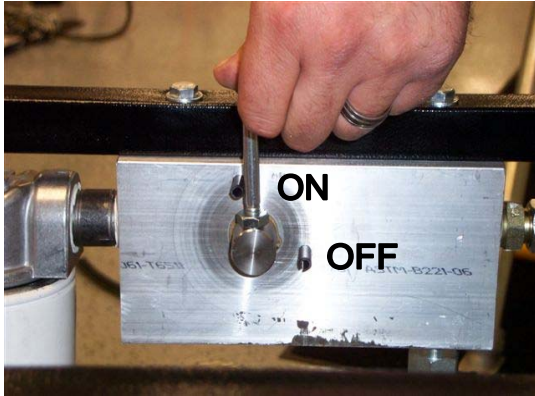

5. Pressure can now be adjusted with the Relief Valve Screw.

6. Loosen Jam Nut.

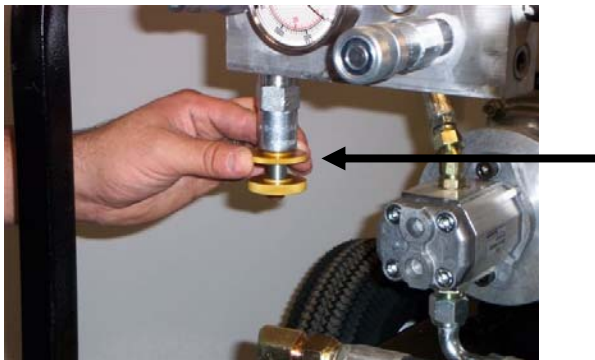

7. Turn Relief Screw (tight - clockwise) to increase pressure; (loosen - counterclockwise) to lower pressure.

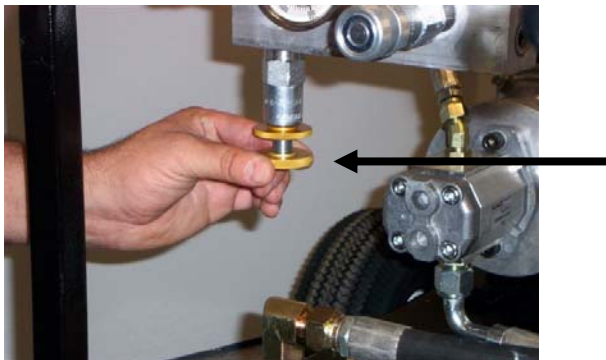

8. Tighten jam nut at desired pressure.

Making the Cut

1. Turn water coolant on (if required by blade type). See Coolant System for operating instructions.
2. Loosen depth control screw with T-Handle wrench.



3. Using the T-Handle wrench, slowly plunge the blade into the pipe, allowing the blade to cut. The blade can be "stalled" if too much pressure is applied while making the plunge cut.

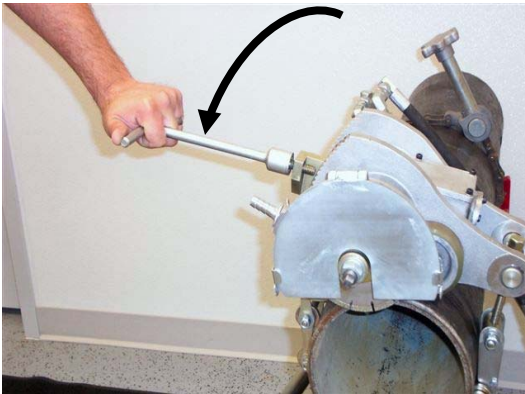

Making the "Plunge" cut



Blade set and cutting pipe

4. Tighten the depth control screw. Make sure that the screw is located on the flat surface, and not on the point. Screw can loosen if not set in proper location. Remove T-Handle Wrench.



5. Flip feed lever to the “ON” (vertical) position. The PipeMaster will now start to travel around the pipe. Check the direction of travel. When facing the blade side of the Pipe Master, the direction of travel will be clockwise. If the PipeMaster is moving in the counterclockwise direction, stop the cut immediately. Retract the blade from the pipe and shut down the Power Pack. See Trouble Shooting Instructions

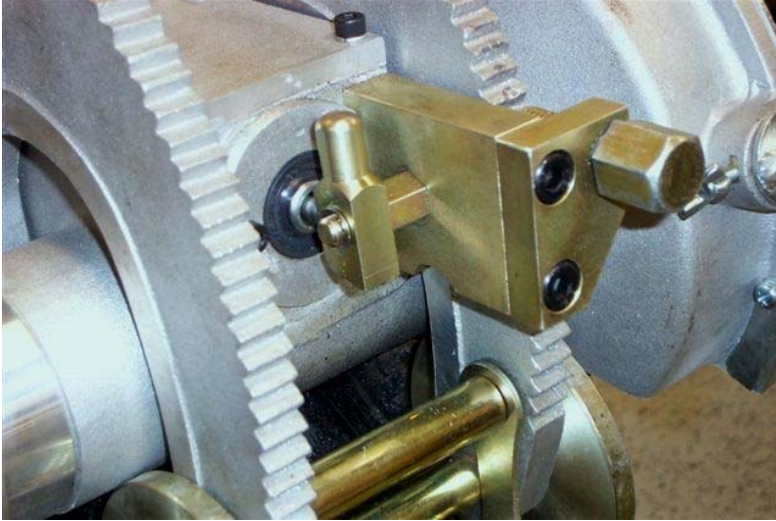

6. The tool should travel on its own for the duration of the cut. However, the operator should watch the progress closely to insure proper operation. Wedges should be installed at a few points around the pipe to avoid pinching the blade; especially once the cutter reaches the bottom portion of the pipe. Be sure that water is always supplied to the blade unless you are using the Wheeler-Rex Blade Part Number 4616.

Coolant System

1. Fill tank with water.
2. Attach hose coupling to coolant nozzle (hose barb end) on the PipeMaster. Tighten the hose clamp to hold rubber hose on metal hose barb.

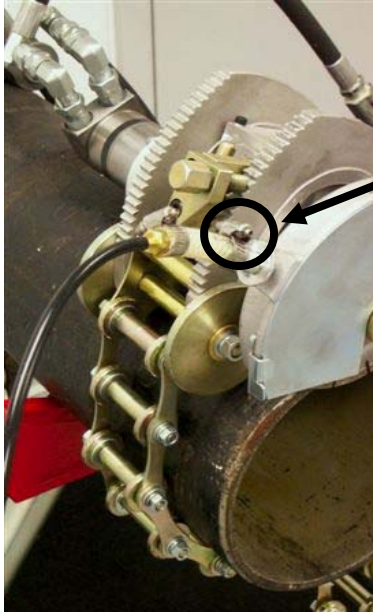

Tighten

3. Turn valve to the "OFF" position. Pump tank up to pressure.



Valve

4. Turn valve to the "ON" position to allow water to spray across blade. Valve can also be used to control the water flow.

Alternative Hydraulic Power Supplies*

If you are not using the Wheeler-Rex Model 6500 Power Pack, the 701185 By Pass Valve (*see following page*) can be used to achieve correct hydraulic outputs to operate the PipeMaster correctly.

Maximum input from alternative hydraulic power source:

0 - 30gpm
0 - 3000psi

Maximum output from By pass valve:

0 - 6gpm
0 - 1500psi

Additional hydraulic lines may be required. (*See accessory page for details*)

* Utility trucks, Backhoes, Skidsteers, Tractors etc.

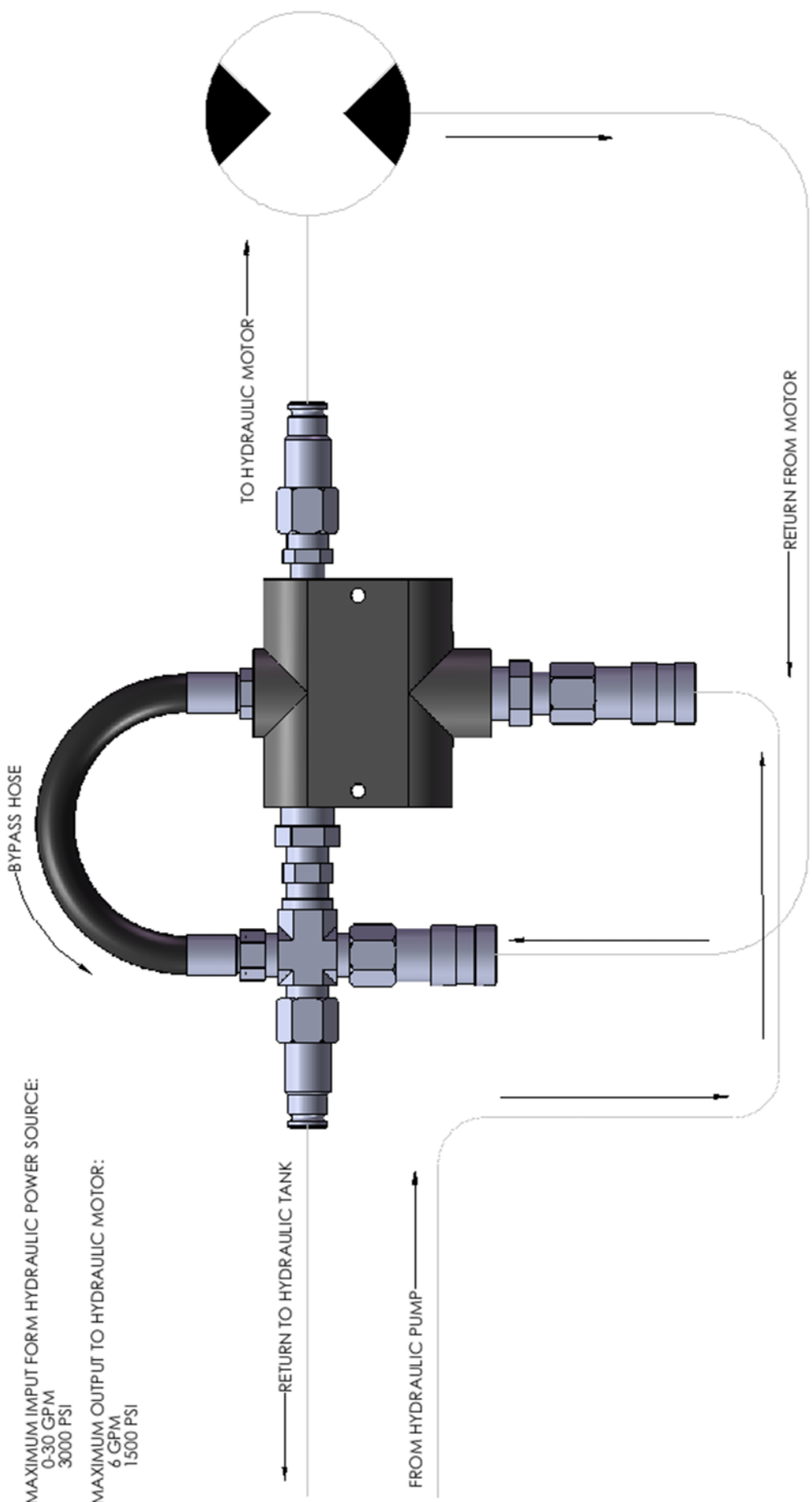

-MAXIMUM INPUT FROM HYDRAULIC POWER SOURCE:
 0-30 GPM
 3000 PSI

-MAXIMUM OUTPUT TO HYDRAULIC MOTOR:
 6 GPM
 1500 PSI

 3744 Jefferson Rd., Ashland, OH 44005
 DESCRIPTION:
 BYPASS VALVE FOR PIPEMASTER
 PART NO. 701185

Troubleshooting

PipeMaster

Problem

Solution

The PipeMaster is moving counterclockwise around the pipe.

- Hydraulic lines need to be switched on hydraulic motor.

Blade not turning

- Check to see if manifold has been turned to the "ON" position.
- Check hydraulic fluid.
- Check to see if hydraulic pump is turning.

Machine won't travel

- Feed lever not engaged
- Drive wheels slipping

Blade binds in cut

- Dull Blade
- Blade Bent
- Pipe is pinching blade, use wedges

Cutting crooked

- Not aligned properly
- Dull Blade
- Improper Chain Tension

Maintenance

PipeMaster

- Make sure tension screw is in good working order.
- Machine and Chain should be cleaned thoroughly and wheels should be free moving after use.
- Prior to storing:
 - Inspect hydraulic hoses for wear before and after use (replace worn or abraded hose immediately)
 - Inspect gear box for leaks before and after use.
 - Check coolant pump hose for leaks and replace if bad

Troubleshooting

Power Pack

Problem

PipeMaster moving counterclockwise around pipe

Solution

- Hydraulic lines need to be switched on hydraulic motor.

Blade not turning

- Check to see if manifold has been turned to the "ON" position.
- Check hydraulic fluid.
- Check to see if hydraulic pump is turning.

Maintenance

Power Pack

- Check engine crankcase for proper oil level before each use. Use and change oil as recommended by the manufacturer.
- Check air filter as recommended by manufacturer.
- Change hydraulic oil filter after the first 25 hours of use. Then change every 50 hours or annually after that.
- Replace the hydraulic oil after every 100 hours of use.
- Use 3 gallons of 10W Hydraulic Oil. (Part #3804 One Gallon of Hydroyl)
- Check hydraulic hoses for wear before and after use and replace worn and abraded hose immediately.

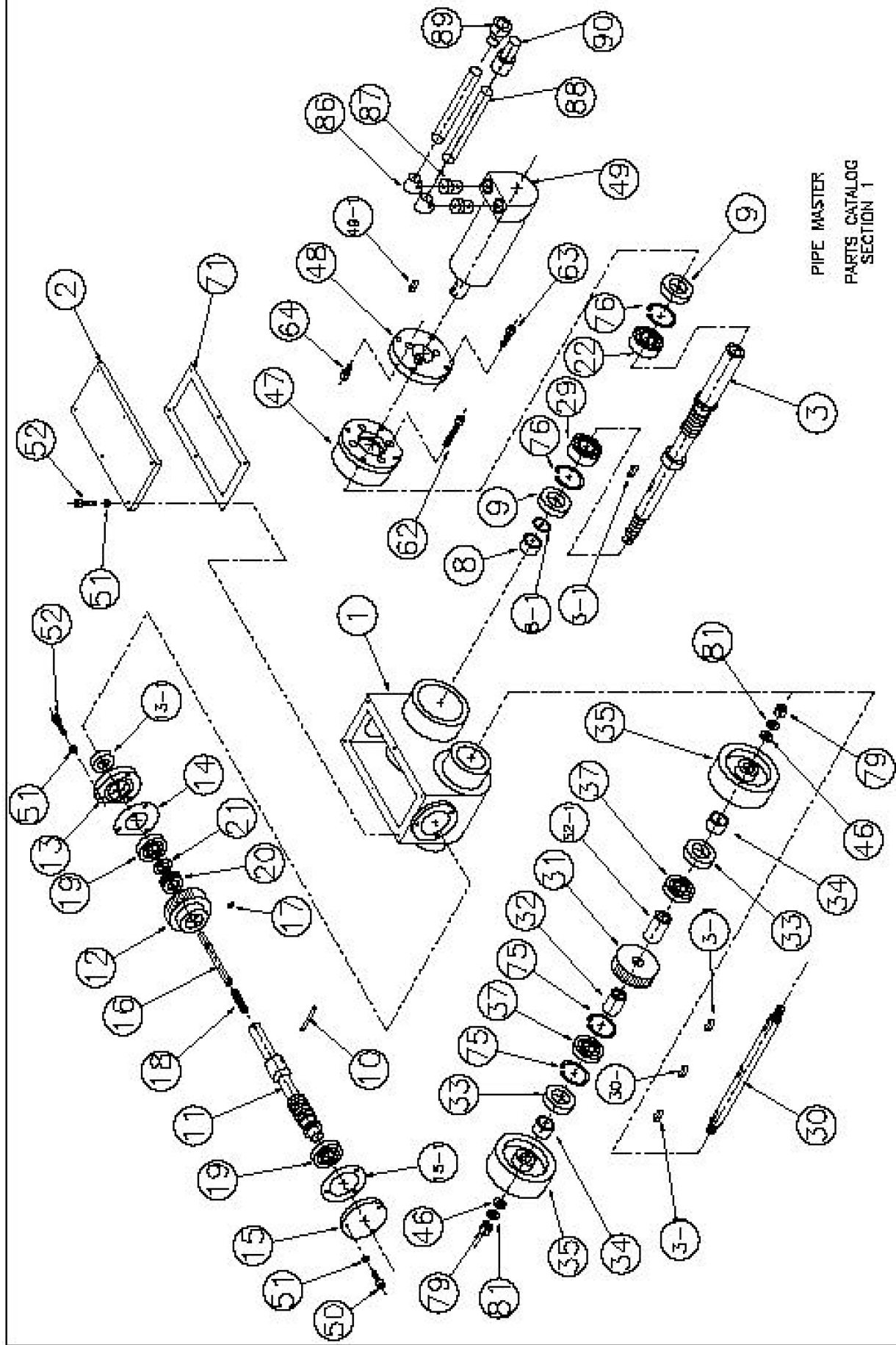

PIPE MASTER
PARTS CATALOG
SECTION 1

SECTION 1

SECTION 1

Ref.No	Part Name	Qty	PN	Ref.No	Part Name	Qty	PN
1	Gear box	1	46021	32-1	Shaft spacer	1	46041
2	Gear box cover	1	46022	33	Shaft seal SD20358	2	46013
3	Blade shaft	1	46024	34	Shaft spacer	2	46042
3-1	Key 5x5x15	3	46025	35	Drive wheel	2	46001
8	Shaft sleeve	1	46026	36	O-ring P-15	2	46014
8-1	O-ring P-20	1	46027	37	Bearing 6202	2	46015
9	Shaft seal SD26428	1	46028	46	Washer M10	2	46043
9-1	Saft Seal SD254510	1	277191	47	Housing	1	46044
10	Feed drive pin 4x34	1	46029	48	Flange	1	46045
11	Worm shaft	1	46030	49	HD Motor	1	276697
12	Worm gear	1	46005	49-1	Key 5x5x16	1	Comes with HD Motor
13	Shaft end plate	1	46031	50	Bolt M5x15	9	46046
13-1	Shaft seal SD15307	1	46006	51	Spring washer M5	12	46047
14	Gasket	1	46032	52	Bolt M5x20	3	46048
15	Shaft end plate	1	46033	62	Bolt M6x35	4	46049
15-1	Gasket	1	46007	63	Bolt M6x20	4	46050
16	Feed on/off shaft	1	46034	64	Bolt M6x10	3	276889
17	O-ring P-5	1	46035	71	Gasket	1	46051
18	Spring	1	46036	75	Snap ring H-35	2	46052
19	Bearing 6202	2	46008	76	Snap ring H-42	2	46053
20	Thrust bearing 51102	1	46009	79	Nut M10	2	46054
21	Bearing collar	1	46037	81	Spring washer M10	2	46055
22	Bearing 6905	1	46010	86	M-O-Ring / F-P Swivel	2	276726
29	Bearing 6004	1	46011	87	90 deg swivel	2	276725
30	Feed shaft	1	46038	88	18" Hydraulic Hose	2	700825
30-1	Key 5x5x20	1	46039	89	FF Female Quick Disconnect	1	276289
31	Secondary worm gear	1	46012	90	FF Male Quick Disconnect	1	276288
32	Shaft spacer	1	46040				

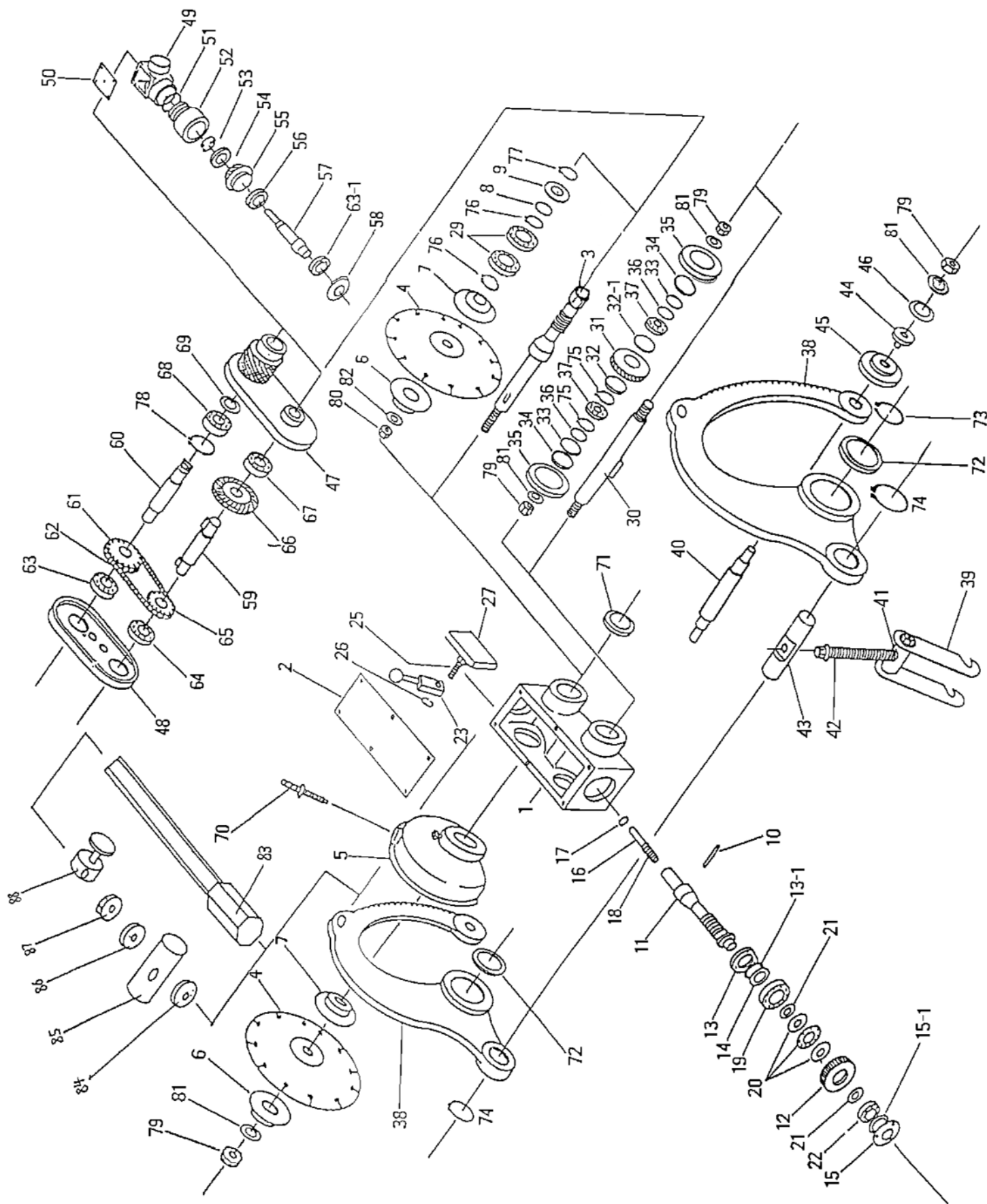

SECTION 2

SECTION 2

Ref.No	Part Name	Qty	PN	Ref.No	Part Name	Qty	PN
1	Gear box	1	46021	53	Plate pin	1	46073
4	Blade for DI & CI	1	4606	54	Chain link	4	46074
4	Blade Economy Diamond for CI	1	4616	55	Link pin	1	46075
4	Blade Carbide tipped for Steel	1	4706	56	Washer M12	2	46076
5	Blade shroud	1	46056	57	Chain roller	2	46077
5-1	Shroud cover	1	46057	58	Washer M8	4	46078
6	Outside collar	1	46002	59	Bush	2	46079
6-1	Outside spacer	1	46058	60	Bolt M8x75	2	46080
7	Drive collar	1	46003	61	Spring washer M8	4	46081
23	Feed engagement	1	46059	67	Thumbscrew M6	1	46082
24	Depth lock bolt	1	46060	68	Nut M6	6	46083
25	Feed engagement pivot	1	46061	69	Thumbscrew M5	1	46084
26	Lock clip E-6	1	46062	70	Water jet	1	46085
27	Bracket	1	46063	72	Bushing Plate	2	46086
28	Depth lock bracket	1	46064	73	Snap ring S-50	2	46087
38	side plate	2	46065	74	Snap ring S-25	2	46088
39	Chain hook	2	46066	79	Nut M10	4	46018
40	axle	1	46067	80	Nut M16	1	46089
41	Pivot shaft chain	1	46068	81	Spring washer M10	4	46017
42	Chain tension screw	1	46019	82	Spring washer M16	1	46090
43	Pivot shaft chain	1	46069	82-1	Washer M16	1	46091
44	Wheel bushing	2	46070	83	Nut M8	2	46092
45	Wheel	2	46071	84	Bolt M4x55	1	46093
46	Washer M10	4	46072	85	Nut M4	2	46094